



THRU-FLOW TRAVELING WATER SCREEN

YOUR FIRST LINE OF DEFENSE AGAINST WATER IMPURITIES

Thru-Flow traveling water screen removes debris such as seaweed, leaves and branches, algae and more—**also safely removes fish.**

Evoqua's Thru-Flow traveling water screens are the industry standard for raw water intake installations in heavy industries adjacent to a water source. These screens ensure clean, debris-free raw water flows through machinery and other channels within a facility. Evoqua's Thru-Flow traveling water screens are the most specified screen in the water intake industry and have been setting the standard for more than 100 years.

The Thru-Flow screen incorporates a non-metallic basket frame with stainless steel mesh. Because the baskets are non-metallic, they won't rust or corrode, making them **environmentally friendly**. Thru-Flow non-metallic baskets are not only stronger and more durable than metallic baskets; they are also up to 50% lighter. This means less wear on drive components, equating to less maintenance overall.

In addition to designing and manufacturing the Thru-Flow traveling water screen, Evoqua serves as the Original Equipment Manufacturer (OEM) for several high-quality and trusted brands recognized in the industry. This includes iconic brands such as **USFilter®**, **Rex**, **Link-Belt**, **Royce** and **FMC**. The Evoqua Thru-Flow screen is designed as a direct replacement for these well-known brands and other traveling water screen brands within the industry.

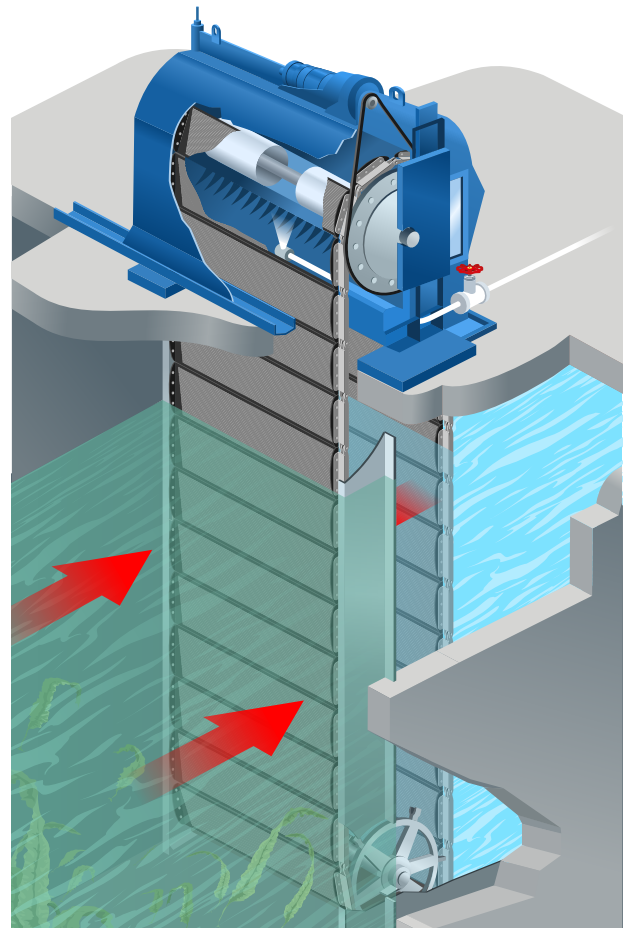

KEY FEATURES AND BENEFITS

- Non-metallic basket frames guarantee superior performance and longevity over conventional steel, with largest debris capacity in the industry with a six-inch lifting lip
- Robust steel main structural framework is able to handle high differential loading
- Non-lube main carrier chain and head shaft bearings to reduce maintenance times and cost
- Roll-around boot tracking eliminates moving parts underwater and also reduces maintenance time and cost
- Easily configurable to meet your exact environmental and specifications needs
- 316(b) Fish Protection-compliant Thru-Flow screen design is available upon request



Submerged screen surfaces are perpendicular to the intake flow, with screen mesh openings sized according to customer requirements and site conditions.

TYPICAL APPLICATIONS INCLUDE:

- Power plant cooling systems
- Water treatment plant raw water intake
- Nuclear power plants (our dive team is safety- and security-rated)
- Cooling tower makeup water systems
- Direct replacement for **Rex**, **Link-Belt** and other screen manufacturers

NEED ADDITIONAL SERVICES?

For customers who are in need of repair, replacement or installation service, Evoqua maintains its own highly qualified **Dive and Service teams**. Each expert team member is safety and security rated and prepared to operate on site.



Evoqua can supply shaft-mounted drives providing greater access to machinery than traditional drive chain applications. Our removable rear splash housing section allows clear access to the baskets and carrier chains.

Made in the U.S.A.

Our manufacturing plant is ISO 9001 Certified and is ISO 14001 Environmentally Compliant.



500 Horizon Dr., Ste. 503, Chalfont, PA 18914

+1 (800) 207-9490 (toll-free)

+1 (215) 712-0280 (toll)

screening@evoqua.com

www.evoqua.com

USFilter® is a registered trademark of Evoqua Water Technologies

All information presented herein is believed reliable and in accordance with accepted engineering practices. Evoqua makes no warranties as to the completeness of this information. Users are responsible for evaluating individual product suitability for specific applications. Evoqua assumes no liability whatsoever for any special, indirect or consequential damages arising from the sale, resale or misuse of its products.

© 2015 Evoqua Water Technologies LLC Subject to change without notice

IN-THRUFLOW-A4-DS-1015