

PACIFIC OZONE™ PGS PEAK OZONE INJECTION SYSTEM



POWERFUL AND VARIABLE FOR LOW TO HIGH OZONE DEMAND

Designed for larger applications, the PGS Peak Ozone Injection System is powerful and configurable to produce and deliver 1.1kg/h ozone. The flexible design allows for multiple operating modes, a suite of integrated instrumentation, and multiple monitoring locations and is also system commission and qualification ready.

The PGS Peak offers great reliability and efficiency, using best practices for ozone treatment making them ideal for mission-critical applications. The system eliminates the complexity of integrating the four integral ozone system elements: feed gas preparation, ozone generation, mass transfer with gas management, and process control. These systems are configured to meet your disinfection needs.

With the Pacific Ozone™ Packaged Generator Systems, all you need is air, water, and electricity to increase the efficiency and safety of your process.

PRECISE CONTROL AND EFFICIENT DELIVERY

Specifically designed for sanitary industrial applications in pharmaceutical, biotech, beverage and food, personal care, and more, all PGS Peak systems are complete, qualified, and fully packaged ozone systems ready for process integration.

PGS Peak ozone systems are complete and self-contained to maximize efficiency and ease for integrating into industrial processes. Precision-controlled Pacific Ozone™ corona discharge ozone generators from Evoqua use oxygen or drop dry air feed gas stock from the integrated feed gas preparation system. After ozone generation, mass transfer and gas management are crucial. PGS Peak systems apply Enhanced Mass Transfer methods derived from computational fluid dynamics (CFD) to deliver the most efficient mass-transfer of ozone gas into solution available.

Precise dissolved ozone concentrations under all operating conditions are imperative to achieve disinfection results. This system combines ultra-efficient injection with gas management and off-gas control to ensure uniform mixing and tight control capabilities not possible in other integrated systems. By placing science in ozone generation and administration, PGS Peak ozone systems deliver safe, tested, and qualified results to be the easiest, highest performing, and trouble-free approach to ozone disinfection solutions.

FEATURES

- Easy-to-Use Software and 10" HMI Touch Screen
- Air-Cooled FPT Titanium Reactor Cells
- No Cooling Water is Required
- Precision Ozone Control by Powertron
- Onboard Oxygen Concentrator
- Stainless Steel Construction
- Integrated Off-Gas Management
- Ambient Ozone Detector with Safety Interlock
- Dissolved Ozone Analyzer
- Ethernet/IP Network Capable

BENEFITS

- Energy Efficient – Low Operating Costs Paired with On-Demand Based Ozone Generation
- Industrial Design with Simplified and Robust User Interface
- System Commission & Qualification Ready
- Automated Start, Stop & Purge Sequencing
- Visual Ozone Indication
- Ideal for Upgrading Existing Systems

MARKETS

- Aquaculture, Food & Beverage, Pharmaceutical



THE POWERTRON DIFFERENCE

Powertron is our latest innovative technology aimed at helping you maximize your operational efficiency. Now integrated into our complete product lineup, this novel power supply design provides a new method to control power for precision O₃ output that uses less energy. With 100% linear turndown capability, this advanced technology provides stabler and quieter performance with its enhanced, robust design. The design offers revolutionary and precise control of the power in the cell to produce the corona, so energy does not become wasted heat. The design allows for unique monitoring of electrical parameters to deliver efficient energy usage reliably while improving performance and reducing maintenance needs.

PEACE OF MIND IN PERFORMANCE

The PGS Peak offers proven and reliable ozone outputs. The performance can easily be verified, when required, delivering qualified and verifiable performance. With the real-time monitoring and the quality design, the units require less maintenance and provide more process uptime to keep your production efficiency high. All PGS Peak systems are engineered to meet all of the ozone process requirements found in the most demanding applications; yet, they are easy simple to operate and easy to move or store, and will provide years of trouble-free operation, providing a solution for today and tomorrow.

SIMPLE. PROVEN. OZONE TECHNOLOGY.

TECHNICAL SPECIFICATIONS

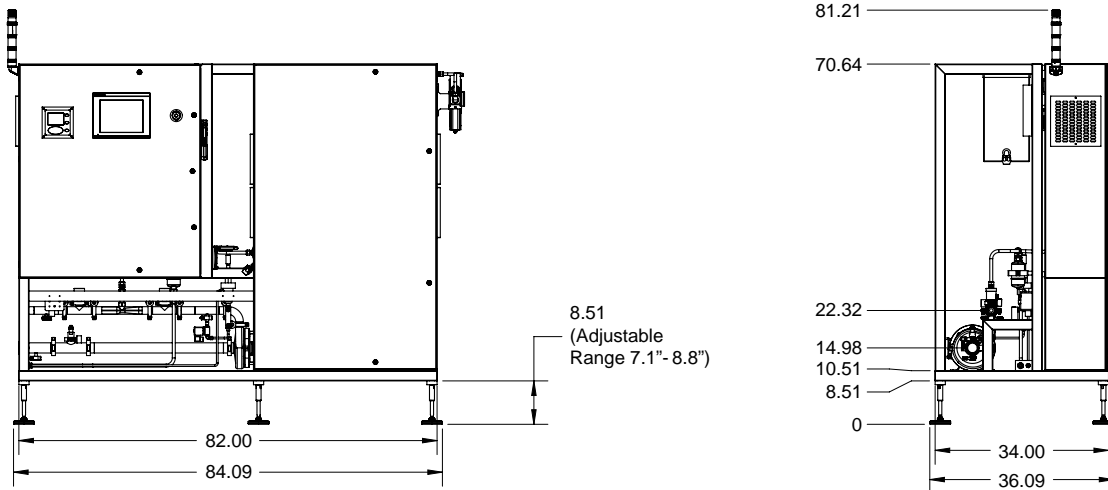

Shown is one typical option without tank. The PGS Peak system is configurable to meet specific requirements. Contact your Evoqua sales team today to learn more about the versatile configurations of the PGS Peak.



558 Clark Road, Tewksbury, MA 01876 USA
 +1 (707) 747-9600 evoqua.com

Pacific Ozone is a trademark of Evoqua Water Technologies LLC, its subsidiaries or affiliates in some countries. All other trademarks are those of their respective owners.

All information presented herein is believed reliable and in accordance with accepted engineering practices. Evoqua makes no warranties as to the completeness of this information. Users are responsible for evaluating individual product suitability for specific applications. Evoqua assumes no liability whatsoever for any special, indirect or consequential damages arising from the sale, resale or misuse of its products.