



MICRO/2000[®] AND DEOX/2000[®] WALLACE & TIERNAN[®] MEASUREMENT MODULE

INSTRUCTION MANUAL

NOTICE

Original instruction manual!

In some countries, DEPOLOX, OSEC, Barrier, Chem-Ad and Wallace & Tiernan are trademarks of Evoqua, its subsidiaries or affiliated companies. No part of this document may be reproduced in any form (printed, photocopy, microfilm, or any other procedure) or saved, processed, copied, or distributed using electronic data systems - without the express prior written consent of Evoqua Water Technologies GmbH.

All information in this document is considered reliable and corresponds to the generally applicable technical standards. Evoqua assumes no responsibility for the completeness of this information. Users are responsible for making sure that the product is suitable for specific applications. Evoqua assumes no liability for specific or indirect damage or consequential damage arising from the sale, resale or misuse of its products.

Important Notice

Evoqua Water Technologies Instruction Manuals are the safety documents for their products. The information provided therein is in accordance with the best practices known at the time of issue and, if fully implemented, should enable the user to operate the plant in the safest possible manner. It is therefore most important that instructions be read and understood prior to the installation, operation or maintenance of the plant.

Notes

Where necessary, special instructions are provided and are quoted under the following headings:

 WARNING
A warning is given in instances where failure to observe the instruction could result in injury to personnel.

 CAUTION
Cautions are given where failure to observe the instruction may result in equipment damage, or pollution to an allied system.

NOTICE
Notes are provided to give additional emphasis to particular points of detail.

The following recommendations are made to ensure safe and efficient operation:

- 1 Only suitably qualified personnel should install, operate and maintain the equipment.
- 2 Only Evoqua Water Technologies manufactured or approved parts should be used.
- 3 The equipment should not be used for any purpose other than that for which it was supplied.
- 4 If equipment being supplied is being put into storage or not being commissioned immediately, or if the plant is being decommissioned, Evoqua Water Technologies urge that they be contacted for detailed advice.

In an effort to make progressive improvements to products, changes in design may be incorporated from time to time, which may not be reflected immediately in the instruction manual. If in doubt, contact Evoqua Water Technologies quoting the equipment serial number; serial numbers are essential for effective communication and proper equipment identification.

The equipment described in this manual may be used with substances that themselves may be hazardous to personnel safety. It is essential that persons employed in the vicinity of such substances be aware of the appropriate safety practices and the location of suitable safety equipment. Provision of safety cards and codes of practice concerning hazardous substance should be made by the supplier of the substance.

Warranty

The equipment supplied is guaranteed against mechanical defect notified to the Seller within a period of 1 year from the date of delivery. For such guarantee to be valid the purchaser must notify the seller in writing immediately such defect becomes apparent. If the Seller so requires, the Purchaser shall return the defective equipment (at the Purchaser's expense) to the Seller. The Seller undertakes that it will, at its own option and its own expense, and by way of full discharge of its guarantee obligation hereunder, either repair, or supply a replacement for the defective equipment, or refund any purchase monies paid to it in respect of any such defective equipment, or portion thereof. If title to the defective equipment is at the time of such replacement or refund vested in the Purchaser, then title shall thereupon vest in the Seller. Replacement material situated outside the U.K. will be supplied F.O.B. U.K. Port. The guarantee given in this clause shall not be operative and enforceable if the equipment is not operated strictly in accordance with the sellers instruction, or in the respect of any defect arising from accident, deliberate act, misuse, neglect or from a breach from the terms of the following clause, or in respect of any defect arising through damage incurred while being transported after delivery of the equipment, or if the equipment has been altered or modified in any way by any person other than the seller, or in respect of any other cause whatsoever which lies beyond the Sellers control.

The Purchaser must comply with all user instructions and safety recommendations issued by the Seller, and must install, commission and maintain the equipment in accordance with good engineering practice, and under the supervision of suitably qualified personnel, and the Seller shall not be liable to the Purchaser for any loss suffered as a result of the Purchaser's breach of the terms of this clause.

Subject to this guarantee all conditions, warranties and representations, whether expressed or implied (by statute or otherwise) relating to the equipment, are hereby excluded in so far as they can be excluded without such exclusion being void or unenforceable at law.

Wallace & Tiernan, Barrier, Chem-Ad, DEPOLOX, OSEC, and V10k are trademarks of Evoqua, its subsidiaries or affiliates.

The designations used in this publication may be trademarks whose use by third parties for their own purposes could violate the rights of the owners. All rights, especially those to duplication and distribution as well as translation, are reserved. No part of this document may be reproduced in any form (printing, photocopying, microfilm or any other method) or saved, processed, duplicated or distributed by the use of electronic systems without the express written consent of Evoqua Water Technologies.

Contents

1	Introduction	8
1.1	Target groups	8
1.2	Structure of the documentation	8
1.3	Conventions.....	8
2	Safety.....	9
2.1	Intended Use	9
2.2	General Safety Instructions	9
2.3	Warranty Conditions	10
2.4	Specific Operating Phases	10
3	Technical Data.....	11
3.1	Specifications.....	11
3.1.1	MICRO/2000® and DEOX/2000® flow block assembly	12
3.1.2	Electrodes and sensors.....	12
4	Description.....	13
4.1	INTRODUCTION	13
4.2	Versions.....	13
4.3	Design.....	14
4.3.1	Electronic module.....	14
4.3.2	MICRO/2000® and DEOX/2000® flow block assembly	14
5	Installation	15
5.1	Scope of Supply	15
5.2	Transport and Storage.....	15
5.2.1	Transport.....	15
5.2.2	Storage	15
5.3	Installation.....	15
5.3.1	Opening the housing	15
5.3.2	Installation with mounting rail (see drawing 50.590.100.050)	15
5.3.3	Installation without mounting rails	15
5.4	Commissioning	16
5.4.1	Installation guide.....	16
5.4.2	Pour in the cell sand	16
5.4.3	Insert the sensor and connect.....	16
5.4.4	Installing reagent hardware (See Dwg. 50.505.020.010)	17
5.4.5	Connecting the sample water	18
5.4.6	Connect the device to the power supply	20
5.4.7	Mounting the housing covers.....	20
5.5	System Shut Down	20

6	SETUP AND CONTROL FUNCTIONS.....	26
6.1	General Information	26
6.1.1	Overall function	26
6.1.2	MICRO/2000® and DEOX/2000® flow block assembly.....	26
6.2	Measurement Inputs	26
6.2.1	MICRO/2000® and DEOX/2000® flow block assembly.....	27
6.2.2	Temperature measurement.....	30
7	OPERATION.....	31
7.1	Display and Operator Controls.....	31
7.1.1	Operator controls	31
7.2	Notes On Operation.....	32
7.2.1	Operation.....	32
7.3	Menu Structure.....	33
7.4	Calibration	33
7.4.1	Temperature calibration	33
7.4.2	MICRO/2000® calibration	34
7.5.1	Error Messages	37
7.5.2	Error	38
8	MAINTENANCE.....	39
8.1	Maintenance Schedules.....	39
8.1.1	Check for tightness	40
8.1.2	Checking the cell sand.....	40
8.2	Maintaining MICRO/2000® and DEOX/2000® Flow Block Assembly	40
8.2.1	Wetside panel removal and replacement.....	40
8.2.2	Occlusion ring removal and replacement	41
8.2.3	Pump rotor, rollers and thrust washer removal and replacement.....	42
8.2.4	Pump tubing units replacement	43
8.2.5	Pump bearing replacement	46
8.2.6	Impeller shaft seal replacement	46
8.2.7	Impeller motor removal and replacement	47
8.2.8	Impeller shaft replacement	47
8.2.9	Pump motor removal and replacement	48
8.2.10	Probe electrolyte and electrodes.....	48
8.2.11	Probe cleaning, refilling and porous element replacement	49

9	Illustrations	50
10	COMPLETE DEVICES , RETRO FIT KITS & SPARE PARTS.....	59
10.1	Retrofit Sets	59
10.1.1	3-electrode cell MICRO/2000® with P T1000	59
10.1.2	3-electrode cell DEOX/2000® with P T1000	59
10.2	MICRO/2000® and DEOX/2000® Spare Parts and Consumables.....	59
10.3	MICRO/2000® and DEOX/2000® Spare Parts List	60
11	APPENDIX A	61
11.1	MICRO/2000® Flow Block Theory of Operation	61
11.2	Preparation of Reagents - MICRO/2000®	61
11.2.1	Preparation of pH4 Buffer	62
11.2.2	Preparation of Potassium Iodide Solution For MICRO/2000®	62
11.2.3	Preparation of Potassium Iodate.....	63
11.3	Refilling Reagent Reservoirs.....	64
11.4	Selection of Reagents	64
11.4.1	Residual Form	64
12	APPENDIX B.....	66
12.1	DEOX/2000® Theory Of Operation.....	66
12.2	Preparation of Reagent DEOX/2000®	68
12.3	Preparation of Potassium Iodide Solution for DEOX/2000®	68
13	EU Declaration of Conformity	69

1 Introduction

1.1 Target groups

This instruction manual provides the information required for installation, operating and maintenance personnel for the installation, operation and maintenance of the MICRO/2000® and DEOX/2000® module.

All personnel working with and on the MICRO/2000® and DEOX/2000® module must have read and understood the instruction manual, particularly the safety instructions.

1.2 Structure of the documentation

This instruction manual contains important information for the safe, trouble-free and economical operation of the MICRO/2000® and DEOX/2000® module. A thorough review of these instructions will help to prevent danger, reduce repair costs and downtimes and increases the reliability and service life of the MICRO/2000® and DEOX/2000® module.

The Chapters Installation and Maintenance are intended only for trained and authorized service personnel. These chapters contain important information on the assembly, configuration, start-up, maintenance and repair, which must be performed by this target group.

1.3 Conventions

This instruction manual contains a number of notes with different priorities that are labeled with pictograms.

DANGER

Immediate danger to life and limb! If the situation is not corrected, death or serious injury will result.

WARNING

Danger to life and limb! If the situation is not corrected, death or serious injury can result.

WARNING



Electrocution hazard.

CAUTION

If this note is not observed, moderate or minor injury or damage to equipment can result.

CAUTION



Environmental hazard!

Do not throw away or burn the batteries!
Batteries must be disposed of at a collection point.

NOTICE

These notes indicate a material risk or provide useful information to make working with the MICRO/2000® and DEOX/2000® module easier.

2 Safety

2.1 Intended Use

The MICRO/2000® and DEOX/2000® Analyser are exclusively designed for measurement and control tasks in conjunction with the SFC or MFC controllers when required for the treatment of waste water, potable water and industrial water.

The operational safety of the unit is only guaranteed if it is used in accordance with its intended application. The unit may only be used for the purpose defined in the order and under the operating conditions indicated in the technical specifications.

Compliance with the intended use also includes reading this operating manual and observing all the instructions it contains. All inspection and maintenance work must be performed at the prescribed intervals by qualified personnel.

The operator bears full responsibility if this unit is put to any use which does not comply strictly and exclusively with the intended use.

2.2 General Safety Instructions

Evoqua Water Technologies attaches great importance to ensuring work on its system is safe. This is taken into account in the design of the system, by the integration of safety features.

Safety Instructions

The safety instructions in this documentation must always be observed. These do not impact on any additional national or company safety instructions.

Safety Instructions on the System

All safety instructions attached to the system itself must be observed.

Technical Standard

The system or unit has been constructed in accordance with state-of-the-art technology and the accepted safety regulations. In the event of the system, or unit, being used by persons who have not been adequately instructed, risks hazard to such persons or third parties and damage to the system or unit itself or to other property are possible. Work described in this operating manual may only be performed by authorized personnel.

Personnel

The operator of the system must ensure that only authorized and qualified specialized personnel are permitted to work with and on the unit within their defined scope of authority. "Authorized specialists" are trained technicians employed by the operator, by Evoqua Water Technologies, or, if applicable, the service partner. Only qualified electricians may perform work on electrical components.

Spare Parts/Components

Trouble-free operation of the system is only guaranteed if original spare parts and components are used as described in this operating manual. Failure to observe this instruction may incur the risk of malfunction or damage to the system.

Modifications and Extensions

Never attempt to perform any modifications or conversions to the unit without the written approval of the manufacturer.

Electrical Power

During normal operation, the control unit must remain closed. Before starting any assembly, inspection, maintenance, or repair work, the system must be switched OFF, and the isolator must be secured against reactivation. Connect all cables in accordance with the wiring diagram.

Waste Disposal

Ensure safe and environmentally-friendly disposal of reagents and replaced part

2.3 Warranty Conditions

The following must be observed for compliance with warranty conditions:

- Installation, commissioning by trained and authorized personnel.
- Intended use.
- Observation of the operational parameters and settings.
- The unit may only be operated by trained personnel.
- An operating log book must be kept.
- Only approved calibration chemicals may be used.
- The unit must not be exposed to ambient conditions outside those specified.
- Maintenance work must be executed at recommended intervals.
- Use of original Evoqua Water Technologies spare parts.

If any of the above conditions are not met, the warranty could be void.

2.4 Specific Operating Phases

Normal Operation

- Never employ procedures which could affect safety.
- Only operate the unit when the housing is closed.
- Inspect the unit at least once daily for externally visible damage and faults. Inform the responsible person/authority immediately of any detected changes (including any changes in the operating performance).
- In the event of malfunctions, switch the unit off immediately. Have malfunctions remedied immediately.

Installation and Maintenance Work

- Always perform installation or maintenance work in accordance with this operating manual.
- Secure the unit against activation during installation and maintenance work.
- Always retighten released screw connections.
- Never use corrosive cleaning agents. Use only a damp cloth to clean the unit.
- Ensure safe disposal of reagents and replaced parts in accordance with environmental regulations.

3 Technical Data

3.1 Specifications

MICRO/2000® and DEOX/2000® measuring module for disinfectant (Micro/2000®) and chlorination/dechlorination (DEOX/2000®)

Sensor input	3 electrode cell
Principle of operation	Potentiostatic amperometry
Temperature drift	< 0.2 %
Linearity error	< 0.1 %
Cell voltage	250 mV
Cell current	1 to 7 µA/mg/l
Temperature input	PT 1000
Measuring range MICRO/2000®	0.100, 0.200, 0.500, 1.00, 2.00, 5.00, 10.0, 20.0, 50.0, 100, 200
Units of measure MICRO/2000®	µg/l, mg/l
Measuring range DEOX/2000® - defined as dechlorination value (-) to chlorination (+)	-0.50 - +0.50, -1.00 - +1.00, -2.00 - +2.00, -2.50 - +2.50, -5.00 - +5.00, -10.0 - +10.0
Units of measure DEOX/2000®	mg/l
Measurands MICRO/2000®	Free chlorine, total chlorine, chlorine dioxide, potassium permanganate, ozone
Measurands DEOX/2000®	Sulphur dioxide - total chlorine Sodium bisulphite - total chlorine
Sensitivity	MICRO/2000® - 0.001 µg/l or 1 % full scale (whichever is greater) DEOX/2000® - 0.01 mg/l or 5 % full scale (whichever is greater)
Protection Category	CE Version Enclosure - (IP 66), CE (NEMA 4X)
Power Supply	230V ± 10%, 50/60 Hz, 15W; Fuse - 200 mA, 5 x 20 mm, fast acting
Operating Conditions	Ambient temperature: 2 to 52°C (35 to 125°F)
	Sample Temperature: -3 to 52°C (26 to 125°F)
	Storage Temperature: -16 to 70°C (4 to 158°F)

3.1.1 MICRO/2000® and DEOX/2000® flow block assembly

Housing	Facade Dimensions	(W x H x D) mm: 330 x 330 x 254
	Weight	approx. 9.1 kg
Connections	Sample water	6mm OD (¼") hose
	Thread connection	13mm (½")
Flow control valve (to sample inlet water line accessories)	Flow rate	MICRO/2000® - approx. 3.8 to 11.4 l/m (1 to 3 US gpm)
		DEOX/2000® - approx. 7.6 to 19 l/m (2 to 5 gpm)
	Control range	0.2 to 4.0 bar (3 to 58 psi)
	Back-pressure	0 bar (0 psi) (free drain)
Sample water	Water quality	ultra pure, potable, industrial, municipal and industrial waste, dechlorinated waste (DEOX/2000®)
	Sample water temperature	max. 50 °C (122 °F)

3.1.2 Electrodes and sensors

MICRO/2000® and DEOX/2000® 3-electrode measuring cell

Measuring system	3-electrode sensor with additional stock of electrolyte salt
Principle of operation	potentiostatic amperometry
Temperature compensation	0 to 50°C (32 to 122°F)
Temperature drift	max. 0.2 % / 10°C
Measuring range	MICRO 2000: 100 µg/l - 200 mg/l DEOX 2000: ±0.50 mg/l - ±10.0 mg/l
Upot	0 to 1000 mV
Reference electrode	silver/silver halide/potassium halide solution
Working electrode	platinum
Storage temperature	-10 to 30°C (14 to 86°F)
Max. pressure	0.4 bar (5 psi) at pump suction
Water quality	clean water, potable water quality, municipal & industrial waste, seawater
Flow	7.6 l/h (2 US g/h), as constant as possible, into sample line
Service Life	life of the electrodes in operation approx. 3-5 years
Cross-sensitivity	ozone, bromine, chlorine dioxide, hydrogen peroxide, strong oxidants

4 Description

4.1 INTRODUCTION

The MICRO/2000® and DEOX/2000® Residual Analyser utilises the same robust measurement system with different set of chemical reagents to cover the full range of analytical measurements. The unit consists of a peristaltic pump, which delivers sample and reagents, a measuring cell and probe. The system is designed to continually measure the level of free or total chlorine residual present in a flow of water and, by control of the chlorine dosage rate, maintain a predetermined chlorine residual level in the treated water. The MICRO/2000® and DEOX/2000® can also be used to control levels of chlorine dioxide or potassium permanganate in a flow of water.

In a MICRO/2000® configuration, the peristaltic pump ensures a consistent flow of sample water to the cell where the residual is measured. Where required for pH buffering and/or total residual measurement, the pump also delivers liquid reagents in fixed proportion to the sample. Potassium iodide liquid reagent must be added to the analyser sample for the measurement of total chlorine residual and acetate buffer to ensure that the sample pH is maintained at pH 4. See Appendix A for further information on the reagents. The system can be used for residuals in potable water, primary or secondary wastewater or cooling water

In a DEOX/2000® system it operates as a centre zero analyser capable of measuring oxidants (Chlorine and Ozone) and reductants (Sulphur Dioxide). Potassium Iodide and Potassium Iodate are mixed with Acetic acid to form Iodine in a mixing coil. This is then injected into the sample stream and subsequently measured as a reduction current by the probe. The presence of oxidant in the sample stream causes excess Potassium Iodide to be oxidised to Iodine resulting in an increase in the measured reduction current, whilst the presence of a reductant in the sample stream results in the removal of Iodine and hence a reduction in the measured current.

Simply, changes above or below the measured Iodine baseline enable the unit to detect both oxidants and reductants. See Appendix B for further information on the reagents. The system can be used for all dechlorination applications.

This manual has been produced to enable the user to obtain maximum service from the equipment and comprises installation, operation, maintenance and spare parts information. Minor changes may be made to the equipment that are not immediately reflected in the manual - if such a change appears to have been made, contact Evoqua Water Technologies for information. Our guarantee is conditional upon the equipment being used in accordance with the instructions herein and we therefore recommend that they be read and fully understood before the equipment is placed in service.

4.2 Versions

The SFC and MFC are available in two different versions (see section 6.1, "Versions"), each in two voltage variations:

- 110 to 230 VAC

Depending on the application, they can be operated either without a flow block assembly (no sensor measuring module) or in conjunction with a flow block assembly and sensor measuring module.

Flow Block Assembly

The flow block assembly is available as below:

- MICRO 2000
- DEOX 2000

4.3 Design

4.3.1 Electronic module

The electronic module consists of a plastic housing with a removable cover. The housing contains:

- IC board
- housing ducts for the cables of the sensor measuring modules
- the cable glands
- the sensor measuring module (optional)

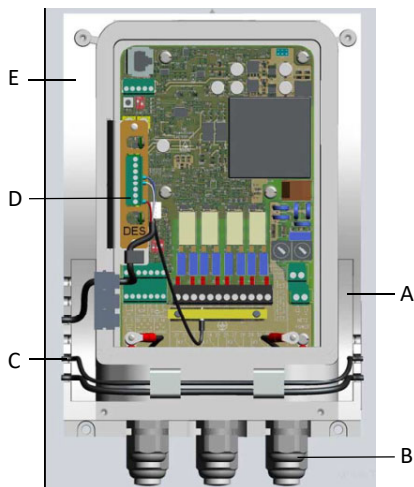

Fig. 1 SFC basic with card and cable

- A IC board
- B Cable glands
- C Housing ducts for the cables of the sensor measuring modules
- D Slot for sensor measuring module
- E Housing

4.3.2 MICRO/2000® and DEOX/2000® flow block assembly

The MICRO/2000® and DEOX/2000® flow block assembly contains the following:

- Cell body with cover
- Flow control valve (mounted externally)
- By-pass strainer (mounted externally)
- Shut-off valve (mounted externally)
- 3 electrode probe for free and total chlorine, chlorine dioxide, ozone, potassium permanganate, sulphur dioxide, sodium bisulphite
- Drain

The cell body can be equipped with one sensor.

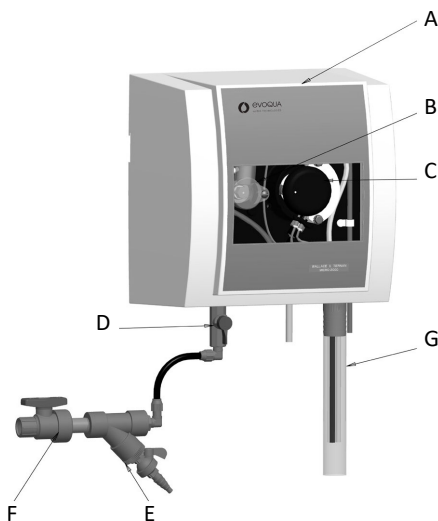

Fig. 2 Flow block assembly

- A Cover
- B Cell body with sensor
- C Peristaltic pump
- D Inlet shut-off valve
- E Bypass Y-strainer with flow control valve
- F Inlet control valve
- G Drain hose

5 Installation

5.1 Scope of Supply

Depending on the individual order, the scope of supply includes the following:

Electronic module including accessories set and mounting set, comprising of:

- 4 x screws Ø 5mm
- 4 x dowels Ø 8mm
- 4 x washers
- 3 multiple seal inserts 2 x 6mm
- 3 multiple seal inserts 4 x 5mm
- 3 reducing sealing rings Ø 8mm
- 4 bolts for multiple seal inserts 5mm
- 2 bolts for multiple seal inserts 6mm
- DIN rail

5.2 Transport and Storage

5.2.1 Transport

The unit is supplied in standard packaging. During transport the packaged unit must be handled carefully and should not be exposed to wet weather or moisture.

Check that the transport packaging is undamaged. In the event of damage please inform the transport company immediately.

If the device is damaged, please contact the respective Evoqua Water Technologies immediately. Keep the packing until the unit has been correctly installed and put into operation.

5.2.2 Storage

Store the unit and the sensors in a dry condition without any residual water in a dry place. Storage temperature, see section 3.1, "Specifications".

5.3 Installation

The device must be protected against rain, frost and direct sunlight and should not be installed outdoors. It must be mounted horizontally on a flat wall with an ambient temperature of 0 to 50°C (32 to 122°F). The air in the room should be non-condensing.

5.3.1 Opening the housing

- 1 Remove the housing cover of the flow block assembly.

5.3.2 Installation with mounting rail (see drawing 50.590.100.050)

- 1 Fasten the mounting rail to the wall with two screws.
- 2 Hook the flow block assembly onto the mounting rail to the left of the electronic module and fasten to the wall with two screws.

CAUTION

The flow block assembly does not need to be mounted directly next to the electronics, it can be mounted on separate mounting rail. The exact location limited by available probe cable lengths.

5.3.3 Installation without mounting rails

When wall mounting the unit it should be screwed to a flat surface through the holes in the corners of the casing, the hole centres for the mounting being 254 mm x 254 mm.

5.4 Commissioning

5.4.1 Installation guide

Commissioning procedure:

Refer to manual W3T168777 for SFC and manual W3T159207 for the MFC.

5.4.2 Pour in the cell sand

Adding grit to MICRO/2000® and DEOX/2000® flow block.

- 1 Remove probe from sample cell.
- 2 Wet finger tip.
- 3 Insert wet finger into supplied grit tube (see Figure 1). Some grit will cling to tip of wet finger (see Figure 2).
- 4 Dip finger into sample cell water, grit will rinse into flow (see Figure 3).
- 5 Replace probe in sample cell.

NOTICE

All the grit in the sample cell should be in suspension, any not in suspension should be removed.



Fig. 1

Fig. 2

Fig. 3

5.4.3 Insert the sensor and connect

- 1 Remove the protection cap from the sensor.
- 2 Install sensor in the cell body cover.

NOTICE

Keep the dust protection cap and watering caps of the sensor for subsequent use.

Arrangement of the plug-in cards and cables:

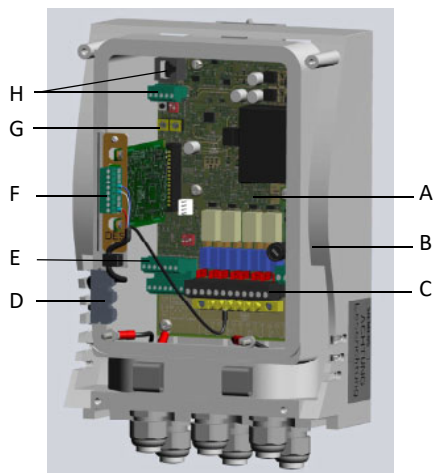

Fig. 4 Electronic Module Cutaway

- A IC board
- B Housing
- C Relay terminal
- D Sensor cable duct
- E Terminal signal inputs/outputs
- F Sensor measuring module
- G Coding switch IC board
- H Connecting plug or terminal at the front panel board

Connecting the sensor cables:

- 1 Place the sensor cables with the attached glands into the cable ducts of the housing.
- 2 Depending on the sensor design, either plug or screw the cable in place.
- 3 Insert the supplied bushes into ducts that are not in use in order to seal housing.
- 4 It is recommended the cable glands in the bottom of the housing be used for routing the MICRO/2000® and DEOX/2000® sensor cable.

5.4.4 Installing reagent hardware (See Dwg. 50.505.020.010)

WARNING

To avoid possible severe personal injury or equipment damage, do not service the metering pump while power is applied to the pump. The motor has enough torque to cause severe pain and injury if fingers are caught in the pumping mechanism.

WARNING

To avoid possible severe personal injury or equipment damage, do not remove the pump occlusion ring while there is any water pressure at the inlet to the analyser. If the pump occlusion ring is removed while pressure is applied to the pump, water (possibly containing acid reagents) can be sprayed from the discharge side of the pump. Sprayed water may result in damage to the equipment or personal injury as it may contain some reagent or may be contaminated.

NOTICE

It is recommended that water-flow to the wet side should be blocked and the reagent reservoirs are not filled until installation is complete. The metering pump may be operated/tested without reagents or water without damage; however, it is advisable to pour enough water into the cell to cover the impeller (mixer) before powering the unit to prevent damage to the impeller shaft seal caused by running the unit dry.

Before attaching the reagent bottle mounting brackets to mounting surface, install the retaining strap through the slots in the bracket. The brackets should be located within 1.2m (4 feet) of the analyser.

- Install the reagent tubing as follows: Uncoil the reagent tubing segment(s) (one per liquid reagent) and remove the rigid tubing segments (1/32-inch O.D., 330mm long (13-inch long)) from the protective packaging. Using two of the three tubing segments, firmly insert one rigid tube into one end of each piece of flexible tubing. Then insert the exposed rigid end into the small hole in the cap of each of the reagent bottles mounted in the bottle brackets. Route the tubing under the facade and connect to the pump reagent tubes.
- For information on installing or replacing reagent tube units, refer to section 8.2.4, "Pump tubing units replacement".
- Tubing Connections: Cut the excess reagent tubing and connect to the reagent fittings at the inlet to the reagent tube units. Install the "T" fitting provided in the tubing at the inlet to (bottom of) the analyser metering pump. To do this, cut the tubing about 25mm from the entrance to the pump and reconnect the tubing using the "T" fitting. This will leave the middle (small) end of the fitting unused.
- If two reagent tube units (two liquid reagents) are used: Install two, one-inch segments of the reagent tubing, cut from the 2.4m (8 foot) segment of reagent tube, on the fittings at the discharge (upper) end of the reagent tube units and join the two segments with the "Y" fitting provided. Using approximately 175mm (7 inches) of reagent tubing, connect the reagent discharge fitting to the tee fitting at the pump sample intake.

5.4.5 Connecting the sample water

MICRO/2000® and DEOX/2000® water sample and sample line requirements:

Actual requirements will vary with the equipment application, but the following should be used as general guidelines. Sample plumbing design is the most important part of a reliable monitoring system.

A well-designed sampling system minimizes response time, prevents fouling of the sample line plumbing and the analyser, and provides a fully developed turbulent flow to the analyser.

Response time is minimized by locating the analyser close to the point of sample take-off and by designing for a moderately high flow velocity in the sample line, 1.5 m/s (5 ft/sec). Flow velocity also helps in reducing sample line deposits.

Plastic pipe or tubing (PVC, ABS, or polyethylene) is preferred for sample line plumbing due to its corrosion resistance, lack of residual demand, and smooth surface finish, which resists deposits. Never use copper pipe or tubing. Avoid the use of metal lines or fittings.

Sample plumbing pipe (or tubing) size is a function of the available pressure at the sample point (or sample pump discharge) along with the sample line length and flow velocity required.

5.4.5.1 Potable Water

Four characteristics typical of potable water are that, generally, it is low in particulates, it is available at reasonably high pressure >1 bar (>15 psi), its use should be minimized, and the wetside may be mounted within 7.5m (25 feet) of the sample point. In such applications, the sample may be run through 6mm (¼-inch) pipe or tubing and the bypass flow on the Y-strainer may be shut. It should be opened only intermittently to flush the strainer element and sample line. Then only approximately 500 ml/min of the sample is required, which is the internal analyser sample requirement.

5.4.5.2 Wastewater

Frequently, wastewater is high in particulates and biological growth potential. The sample is taken from open channel flow, with no pressure available at the sample point. Additionally, the wetside must frequently be mounted a significant distance from the sample point (inside and protected from weather). Here, a sample pump is required and the Y-strainer bypass flow valve should be open to allow continuous flushing of the strainer element. A high flow, low pressure, open impeller type pump works well in this environment. Typical systems use ½-inch pipe or tubing that bypasses 7.6l/m (2 US gpm) through the Y-strainer or 3/4-inch pipe that bypasses 19l/m (5 US gpm). This results in a flow velocity of about 1.2m/s (4 feet/s) and a pressure drop of about 0.3 bar (4 psi) per 30m (100 ft) of sample line.

Wastewater will frequently exhibit high biological growth potential; therefore, the sample line may need to be treated with a cleaning (biocidal) agent (typically chlorine) to inhibit growth in the sample line. Biological growth may clog fittings in the sample line or wetside and consume (process) chlorine residual during the sample transit time in the sample line. For sample line dosing, the cleaning agent is periodically injected into the sample line near the sample intake point.

A self-flushing, 1/2-inch Y-strainer is provided and should be located at the analyser. Valves are provided to be installed on the Y-strainer bypass discharge to control bypass flow and at the filtered discharge from the Y-strainer to the 1/4-inch sample inlet at the base of the flow block.

The analyser enclosure is equipped with a hose adapter drain connection for 1-1/4-inch hose.

- 1 Slip 1-1/4 inch drain hose over the end of the drain fitting and run hose to a waste drain.
- 2 Connect a hose from the Y-strainer bypass valve to the waste drain.
- 3 Inside the wetside, insert the analyser bypass tubing and cell discharge tubing (both 1/4-inch OD translucent) into the drain fitting.

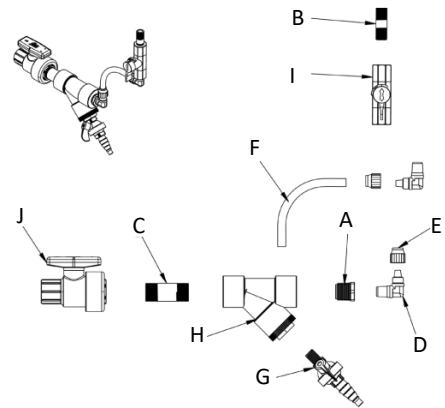

Fig. 5 MICRO/2000® and DEOX/2000® sample line

- A Reducing Bushing, 1/4" x 1/2" NPT
- B 1/4" x 1/4" Nipple
- C 1/2" Nipple
- D 90° Elbow
- E Nut-Union, 1/2-20 Thread
- F 1/4" ID Tubing
- G Valve
- H Y-Strainer
- I 1/4" T x T Labcock Valve
- J 1/2" Single Entry Ball Valve

5.4.6 Connect the device to the power supply

WARNING

Only authorized and qualified electricians are permitted to install the device and open the housing. The device may only be taken into operation when the housing is closed, and must be connected to protection earth. Modifications to the device which go beyond those described in this manual are not permissible.

WARNING

The device is not equipped with a mains switch and is in operation as soon as the supply voltage is applied. When connecting system components (e.g. devices, motors, pumps), the system components must be switched off.

CAUTION

To ensure safe and correct commissioning, knowledge of the operation, connected electrical load, measurement signals, cable assignment and fuse protection of the connected devices and machines and the relevant safety regulations is required. The device may only be commissioned by qualified and authorized electricians. Incorrectly connected devices can be damaged, possibly irreparably, or cause faults in other equipment when they are switched on or in operation. Ensure that the measuring and control cables are not confused or make contact with one another. Never connect or disconnect any cables to which voltage is applied.

NOTICE

Refer to manual W3T168777 for SFC fusing details and manual W3T159207 for the MFC fusing details.

5.4.7 Mounting the housing covers

- 1 Carefully place the housing cover onto the flow block assembly and drop into place.

5.5 System Shut Down

CAUTION

Danger of uncontrolled dosing of chlorine or pH correction medium: Shut down dosing system, close positioner!

NOTICE

If the installation site of the flow block assembly is not frost free, the system must be shut down prior to any possible frost formation.

- 1 Switch off the power supply.
- 2 Drain the sample water supply line and drainage line (hold container underneath).
- 3 Empty cell bodies and remove grit.
- 4 Dismantle the filter housing and/or check valve housing.
- 5 When the remaining water has drained from the flow control valve, refit the filter housing and the check valve housing.
- 6 Remove the sensors from the cell body cover and disconnect from the cable.

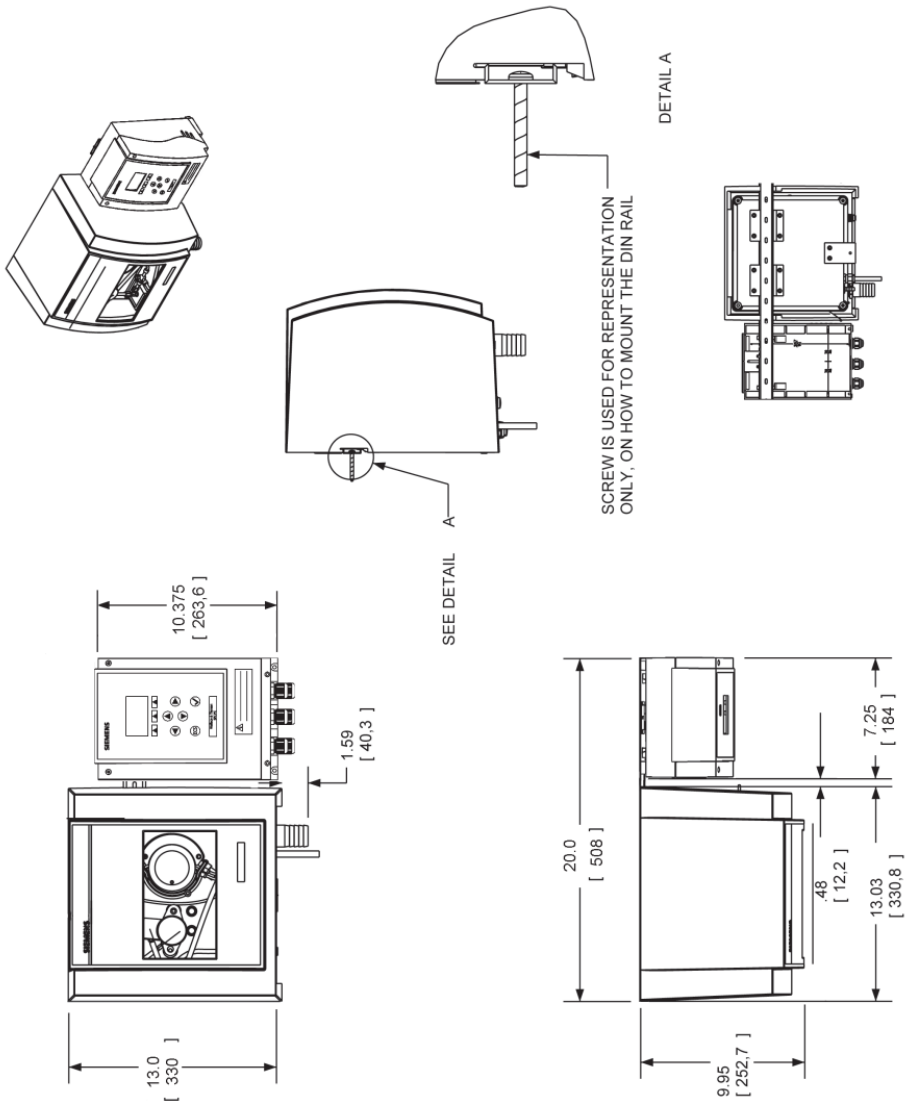

Fig. 6 TOP HAT RAIL ASSEMBLY - DIMENSIONS MICRO/2000® and DEOX/2000® Flow Block 50.590.100.050 - ISSUE 1: 7-14

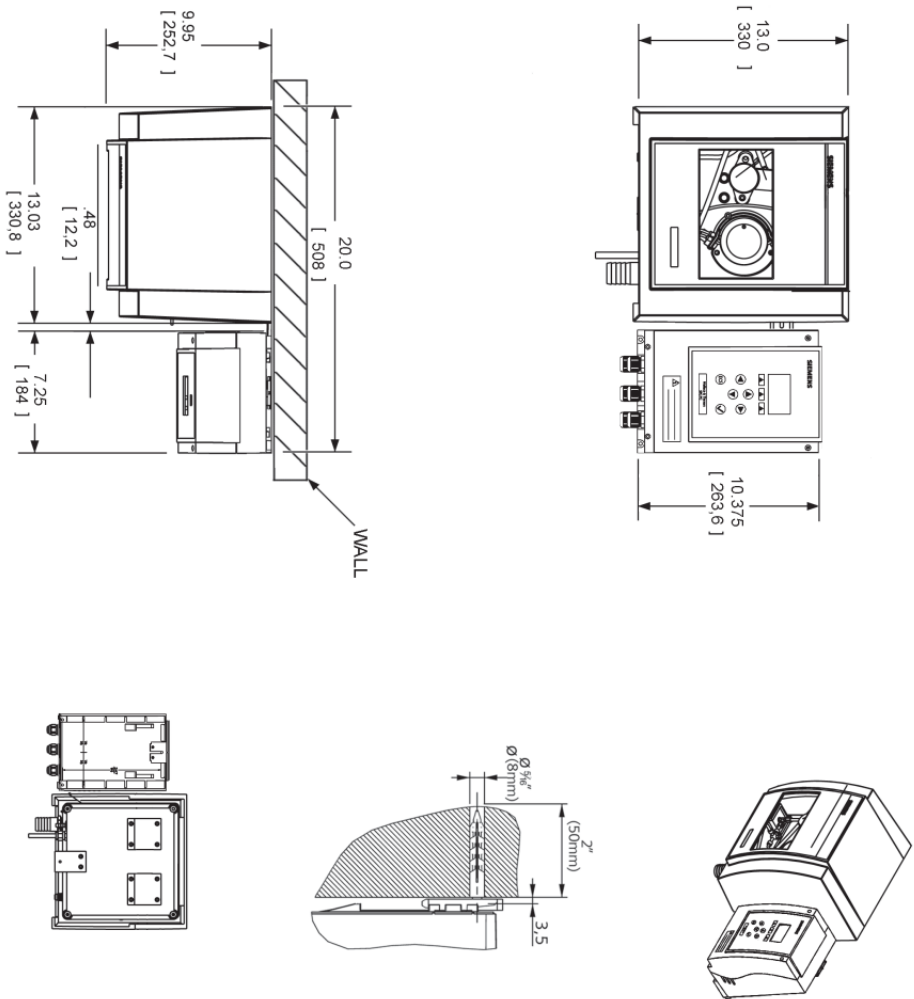

Fig. 7 WALLMOUNT ASSEMBLY - DIMENSIONS MICRO/2000® and DEOX/2000® Flow Block 50.590.100.060 - ISSUE 1: 7-14

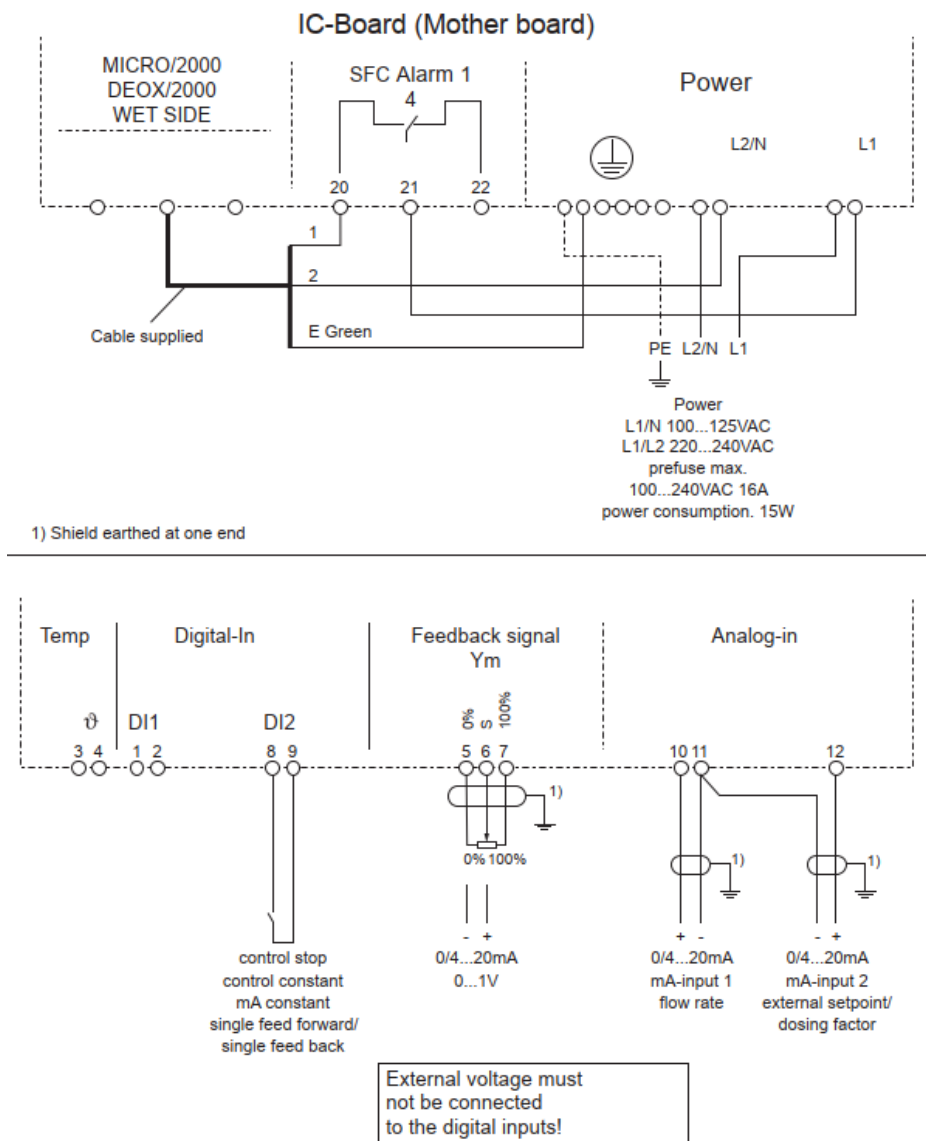

Fig. 8 SFC - SCHEMATIC WIRING 50.585.155.050A - ISSUE 1: 1-11

Relay Outputs - MICRO/2000 - DEOX/2000
Wet Side Power Connection

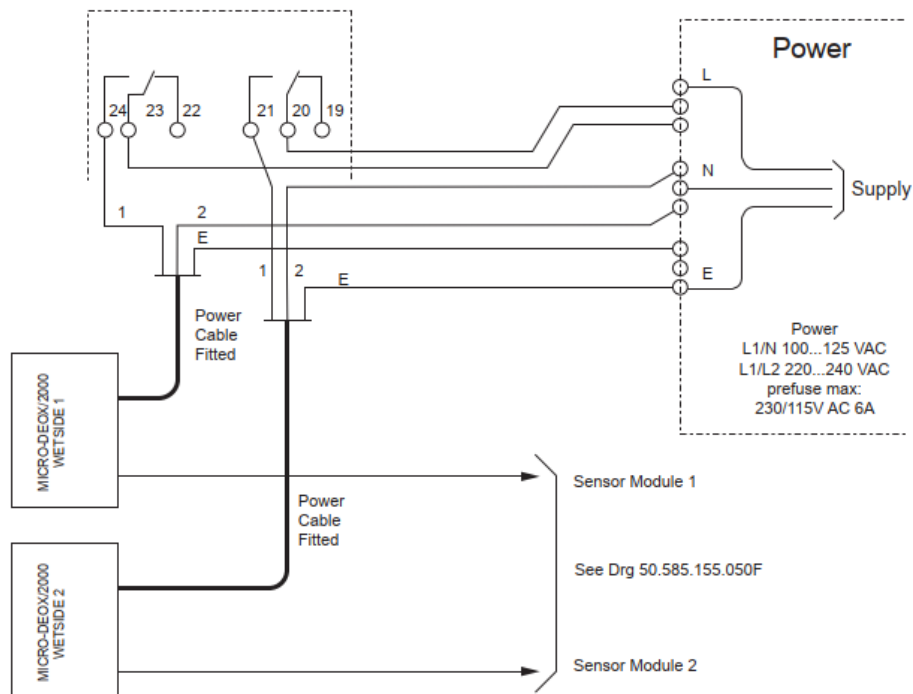

Fig. 9 MFC - SCHEMATIC WIRING 50.585.155.050B - ISSUE 1: 1-11

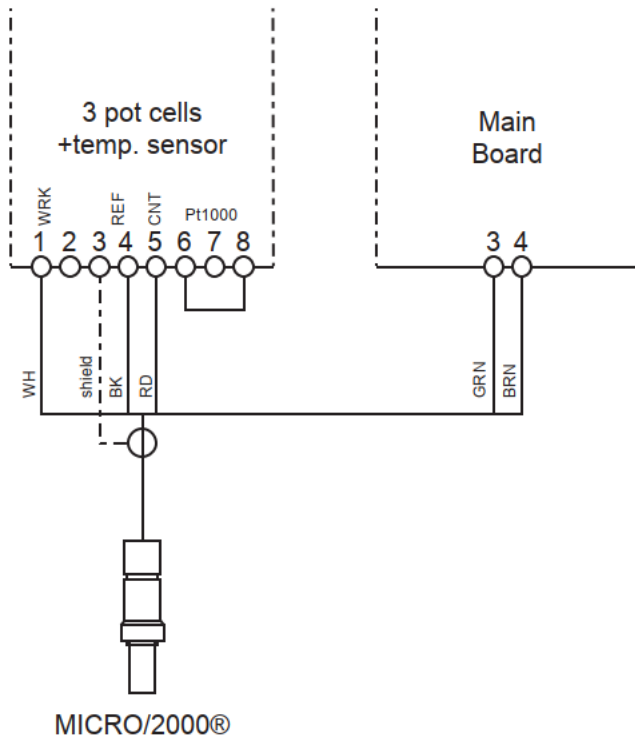

Fig. 10 SFC Sensor/Module Connection for CE Version 50.585.155.050F - ISSUE 0: 9-10

6 SETUP AND CONTROL FUNCTIONS

6.1 General Information

The SFC and MFC are measuring and control devices for use on potable water, industrial process water and waste water.

Typical applications:

- Measurement and monitoring of water parameters
- Chlorine single feedback closed-loop control

Possible process measurements are:

- free chlorine
- total chlorine
- chlorine dioxide
- potassium permanganate
- sulphur dioxide
- sodium bisulphite

As an option, two additional control signal inputs can be installed to log flow rate and external setpoint using combi-control or ratio control.

The integrated graphic display shows the following:

- Measured values
- Mode
- Bar graph with limit values
- Setpoint and measuring range
- Description of customized measuring points
- etc.

The menus are easy to use, displayed in plain text and are selected using softkeys.

6.1.1 Overall function

Possible measured values:

- Free chlorine*, total chlorine*, potassium permanganate*, chlorine dioxide* ozone* (MICRO/2000® 3-electrode cell)
- Total chlorine*, sulphur dioxide* (DEOX/2000® 3-electrode cells)

* These measurements are automatically temperature-compensated.

The graphic display shows the measured data, limit values and setpoints as numeric values, diagrams or a trend line.

6.1.2 MICRO/2000® and DEOX/2000® flow block assembly

These flow block assemblies guarantee a stable measurement signal with:

- Robust sensors
- Constant flow rate with the aid of the flow control valve
- Hydrodynamic grit cleaning of the Depolox® 5, MICRO/2000® and DEOX/2000® flow block electrodes
- Optimum flow around all sensors

6.2 Measurement Inputs

In principle, the following sensor measuring module types or retrofit kits can be installed at the module slot. The sensor measuring modules are only supported in applications 1 and 2:

DES - for MICRO/2000® analyser with PT1000

DES - for DEOX/2000® analyser with PT1000

When the device is switched on, the menus are initialized according to the installed sensor module. If the sensor modules are changed at a later date, the user menus are automatically initialized when the device is switched on. If no sensor measuring module is installed when the unit Version 1, the message "No measurement available" appears.

The sensor measuring module should be considered as the main measurement, and control functions such as ratio control, single feedback closed loop, and combi-control are supported depending on the Process Control option. No controller output is available for application 1.

6.2.1 MICRO/2000® and DEOX/2000® flow block assembly

MICRO/2000® and DEOX/2000® Flow Block Assembly - 3 Electrode Measurement for Total and Free Cl_2 , ClO_2 , O_3 , or KMnO_4 (MICRO/2000®), Total Cl_2 and SO_2 or NaHSO_3 (DEOX/2000®).

A sensor module ("DES" for 3 electrode cells) and terminal strips are used to connect the MICRO/2000® and DEOX/2000® flow block assembly to the SFC. Various controller functions are available depending on the application selected.

6.2.1.1 MICRO/2000® flow block theory of operation

The measurement of free chlorine is made directly at a buffered pH of 4 with pH 4 buffer. The measurement of total chlorine is made by reacting the various chlorine species with potassium iodide at the buffered pH, then measuring the resulting iodine concentration.

The net reaction of chlorine with iodide is:

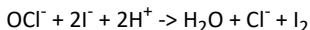
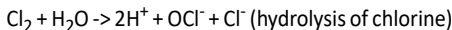

The analyser measuring process is as follows:

A continuous sample is delivered to the analyser. A flushing Y-strainer divides the sample into two streams-the larger bypass stream continuously flushes the Y-strainer and the smaller stream, about 500 ml/min, flows into the analyser. Most of the flow into the analyser is again bypassed, but a small portion (15 ml) is metered from this flow by a peristaltic metering pump. The reagents, pH 4 buffer for the measurement of free chlorine residual and potassium iodide solution for the measurement of total chlorine residual, are also metered by the same pump. The reagents are then mixed with the sample as the sample is pumped to the analyser cell. A three-electrode amperometric "probe" is immersed in the sample in the cell. A rotating impeller stirs the sample and maintains a constant sample velocity across the electrode surfaces. It also agitates the grit used to clean deposits from the electrodes, improving the stability of calibration. The amperometric cell produces a signal (electrical current) proportional to the oxidant (e.g., chlorine) concentration in the cell.

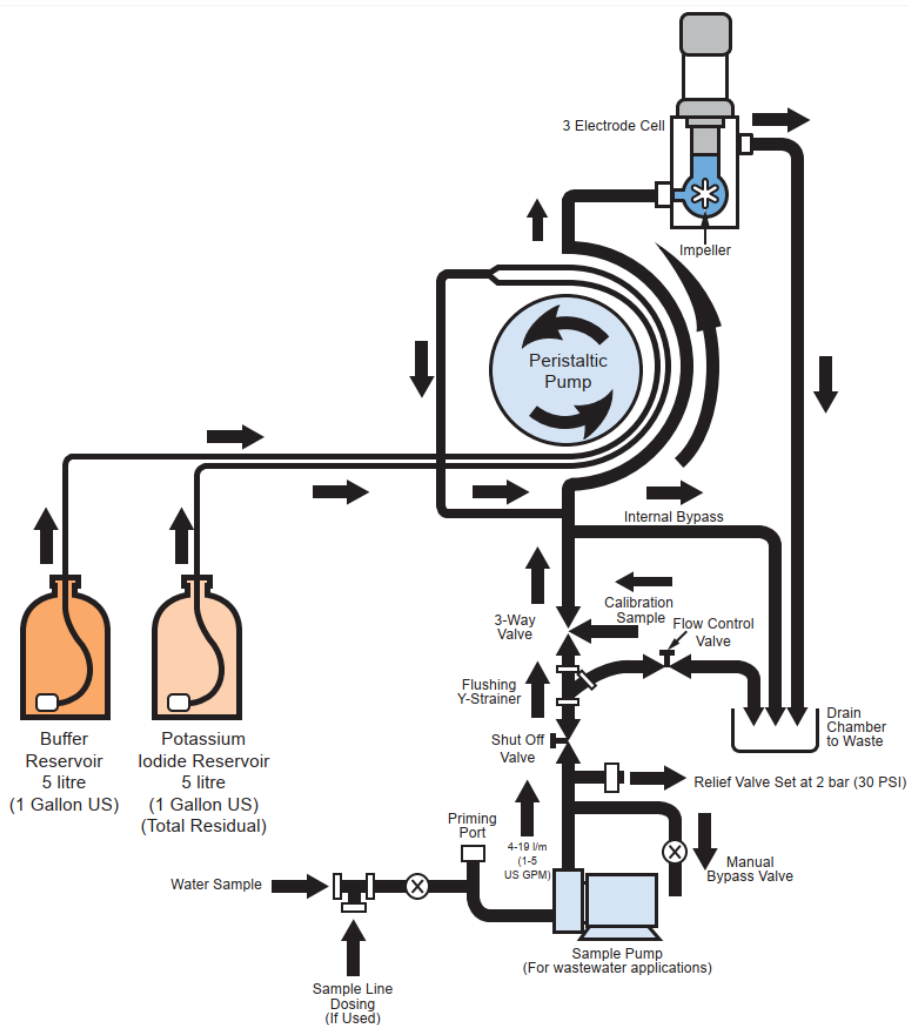

Fig. 1 Flow Diagram

6.2.1.2 DEOX/2000® flow block theory of operation

The DEOX/2000® Analyser gives a continuous on-line determination of SO₂ residuals by metering a predetermined amount of Potassium Iodate, along with pH4 buffer and potassium iodide, into a metered quantity of process water sample. This constant level addition of iodine is termed the "Iodine Bias". The DEOX/2000® analyser detects this iodine level as a proportional electric current (μA) in the same manner it does with chlorine. Once in operation, change in current indicates the presence of a chlorine or SO₂ residual in the process water—depending on whether the change is an increase or decrease in iodine concentration, respectively. Iodine reacts with SO₂ in the same manner that chlorine reacts with SO₂, therefore, the amount of iodine consumed represents the amount of SO₂ residual in the water. Conversely, if there is an increase in the iodine concentration (above the bias concentration), a chlorine residual is indicated and can be accurately determined.

Iodine is used as the "biasing reagent" because it is less likely (and slower to react with organic oxidant demand, making determination of residuals more reliable than a hypochlorite (chlorine) biased measurement. Because iodine is not stable in solution (i.e., is volatilized and reacts readily), Potassium iodate solution is reacted with potassium iodide (KI) and releases iodine as used. This conversion reaction takes place in the long length of "reaction" tubing where the mixed reagents react before entering the water sample.

The analyser measuring process is as follows:

A continuous sample is delivered to the analyser. A flushing Y-strainer divides the sample into two streams—the larger bypass stream continuously flushes the Y-strainer strainer element and the smaller stream, about 500 ml/min, flows into the analyser. Most of the flow into the analyser is again bypassed, but a small portion is metered from this flow by a peristaltic metering pump. The reagents, Potassium Iodate in pH4 buffer and potassium iodide in distilled water, are also metered by the same pump.

As the reagents are discharged from the pump, they are combined and reacted in a length of tubing referred to as the reaction tubing. The reacted reagents are then mixed with the sample inlet to the metering pump and the "Biased" sample then enters the analyser cell. A three-electrode "probe" is immersed in the sample in the cell. A rotating impeller stirs the sample and maintains a constant sample velocity across the electrode surfaces. It also agitates the grit used to clean deposits from the electrodes, improving the stability of calibration. The three-electrode amperometric cell produces a signal (electrical current) proportional to the oxidant (iodine) concentration in the cell.

6.2.1.3 Sample flow adjustment

Before starting the sample pump or otherwise starting sample flow, check that the bypass control valve on the bypass leg of the Y-strainer, at the analyser, is open and that the sample flow control valve to the inlet of the analyser is closed.

CAUTION

To prevent possible equipment damage, apply up to a maximum of 0.3 bar (5 psi) water pressure to the analyser sample input. The tubing in the analyser metering pump cannot withstand more than 5 psi pressure. If pressure in excess of 0.3 bar (5 psi) is applied to the analyser input, fluid may be sprayed from the analyser metering pump inlet.

CAUTION

Pressures in Excess of 0.3 bar (5 psi) will cause the the tubing passing through the peristaltic pump to expand resulting in an increase in flow and hence a change in the dilution ratio. Ideally the flow to the drain should not be any more than a constant drip.

6.2.1.4 Probe installation

The probe should be installed in the analyser after the rest of the analyser installation (mounting, plumbing, wiring) is completed and inspected.

CAUTION

Do not fill the probe with electrolyte until immediately before it is installed in the analyser. Once the probe is filled with electrolyte, the electrode end must be kept wetted, as it is when installed in the analyser. If the probe is filled and the porous element is allowed to dry, the pores will clog with potassium chloride crystals.

Fill the probe (through the fill hole in the side of the probe body) with electrolyte. Fill only to a level just below the fill hole when the probe is upright. The hole plug is not watertight.

Remove the protective cap from the electrode end of the probe. Check that the electrodes are clean; wipe clean with a paper towel if necessary. Do not touch the electrodes (platinum elements) or the porous element (white element), as finger dirt or oil may impede the probe operation. The platinum material is thin and easily punctured or sheared off. The electrodes are not repairable.

Allow the probe to stand upright (or hang it by its cord) for about ten minutes until electrolyte emerges from the porous element. If the electrolyte does not emerge shortly, it can be forced through the porous element by pressurizing the reservoir with a rubber squeeze bulb - used to force air into the fill hole. Use a sharp blade or a pointed object to cut a small vent hole in filling hole plug, enough to allow air through and equalize to atmospheric pressure on both sides of the plug. Replace the hole plug to prevent evaporation of the electrolyte.

Connect cable to input module.

6.2.2 Temperature measurement

The IC board of SFC has a temperature measurement for connecting a PT 1000 sensor (multi-sensor). This temperature measurement is used for temperature compensation of the "DES" module and pH measurement. The temperature is shown on the main display and can be calibrated if necessary. The measuring range is 0 - 50 °C. The unit may be adjusted to °F.

7 OPERATION

7.1 Display and Operator Controls

Graphic display and operating panel

All information is shown on the graphic display.

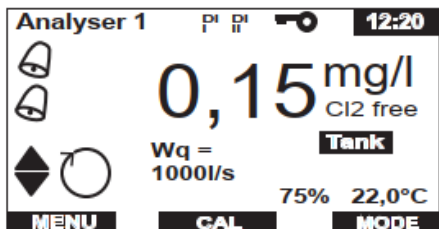

Fig. 1 Graphic display

The SFC is operated with nine keys. The software function is controlled with the top three keys (softkeys).

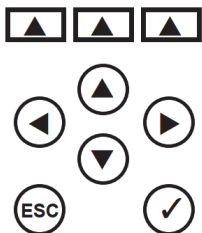

Fig. 2 Operating panel

The exact depiction of the individual parameters on the graphic display is described in section 7.3, "Menu Structure".

7.1.1 Operator controls

Symbols	Meaning
	Softkey <ul style="list-style-type: none"> Activate the function shown on the graphic display with the keys.
	Up <ul style="list-style-type: none"> Move up one level. Display the previous option. Increase the value.
	Down <ul style="list-style-type: none"> Move down one level. Display the next option. Decrease the value.
	Left/right <ul style="list-style-type: none"> Change the column in the menu. Change the position in the displayed value (cursor menu). Move forwards or backwards by six hours in the trend graph.
	Escape <ul style="list-style-type: none"> Cancel the entry without saving the new value. Move up one menu level.
	Enter/Acknowledge <ul style="list-style-type: none"> Acknowledge alarm message. Set the running delays to zero. Delete adaption error. Acknowledge max. dosing time to reactivate dosing.

7.2 Notes On Operation

During operation observe the following points:

- Check your entry and modifications before exiting the menu.
- Only press the keys with your fingers, never with hard or pointed objects such as pencils, etc. This could damage the sealed keypad.

7.2.1 Operation

You have the following options starting from the basic display (the basic display is opened by pressing the "ESC" key in the menu four times):

Switch between the basic displays and trend graphs	<ul style="list-style-type: none"> • Press the up or down key
Select menu	<ul style="list-style-type: none"> • Press the "MENU" softkey to select the menu • Press the "CAL" softkey to calibrate • Press the "MODE" softkey to set the operating mode
Select a menu item in the menu display	<ul style="list-style-type: none"> • Select the parameter with the arrow keys (arrow in front of parameter) • Confirm the selection with "ENTER" • Change/enter the display with the up or down arrow keys • Confirm the entry with "ENTER"
Cancel entry	<ul style="list-style-type: none"> • Press the "ESC" key to exit the menu item. <p>Entries which have not been confirmed are reset to their original settings.</p>
Reactivate password protection	<p>This function is only active when a password has been programmed.</p> <ul style="list-style-type: none"> • Change/enter displayed parameters • Block the system entry with the "LOCK" softkey in the menu display
Exit the menu item	<ul style="list-style-type: none"> • Press the "ESC" key <p>or</p> <ul style="list-style-type: none"> • Press the "BACK" softkey

7.3 Menu Structure

The SFC and MFC have various menus:

- Main menu
- Module type, e.g. Cl2 free 1
- Inputs/Outputs
- Alarms
- System
- Diagnosis
- Calibration
- Mode

Display of these depend on the number of sensor measuring modules installed.

NOTICE

For full menu details refer to manual W3T168777 for SFC and manual W3T159207 for the MFC.

The "Calibration" and "Mode" menus are opened with the corresponding soft keys directly from the basic display. All other menus can be accessed with the "MENU" softkey.

7.4 Calibration

CAUTION

The electrode fingers or membranes on the sensors are extremely sensitive. Do not touch, soil or damage them.

NOTICE

To prevent loss of control during calibration, the "Hold function" in the system/common menu should be set to "On" (mA-outputs and controller outputs then remain constant during calibration). To determine how often you must calibrate, refer to section 8.1, "Maintenance Schedules".

7.4.1 Temperature calibration

- 1 Starting from the basic display in the main menu select the "Calibration" menu.
- 2 Select the "Temperature" menu item The "Calib. temperature" window appears on the graphic display.
- 3 Select "Cal. temperature".
- 4 Perform comparative temperature measurement.
- 5 Open the menu with the "Enter" key and enter the ascertained value with the arrow keys.
- 6 Save the value by pressing the "Enter" key.

NOTICE

°C or °F can be selected in the "Temp. unit" menu. The required temperature input can be selected or switched off in the "Temp. sensor" menu.

7.4.2 MICRO/2000® calibration

Before beginning calibration, choose the method of calibration (1 point or 2 point).

7.4.2.1 One point calibration

Grab Sample Method

- 1 Select the 1 Point calibration method in the calibration menu.
- 2 Once the reading on the system is stable, collect a sample from the water line.
- 3 Measure the residual contained in this sample.
- 4 Enter this value as the "SPAN" value.

Standard Solution Method

- 1 Select the 1 Point calibration method in the calibration menu.
- 2 Create a 500 ml sample solution of a desired concentration within the intended operating range.
- 3 Allow the sample solution to pump through the sample line for a minimum of 10 minutes using the 3-way inlet valve (see Figure 3).
- 4 When the display stabilizes, enter the solution concentration (mg/l) as the "SPAN" value.

7.4.2.2 Two point calibration

- 1 Select the 2 Point method of calibration in the calibration menu.
- 2 Obtain 500 ml of demand free water.
- 3 Allow the demand free water to pump through the sample line for a minimum of 10 minutes using the 3-way inlet valve (see Figure 3).
- 4 Once the reading is stable, enter this value as "ZERO".
- 5 Complete "Grab Sample Method" above for "SPAN" calibration. This concludes the MICRO/2000® calibration.

7.4.2.3 Calibration tips

Because the analyser is on-line, the process should be observed for a few moments before and while taking the sample to ensure that the process does not deviate suddenly during sample taking and before initiating the calibration. A substantial change in the process during calibration results in an inaccurate calibration.

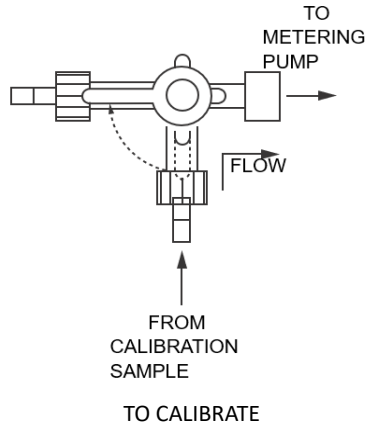
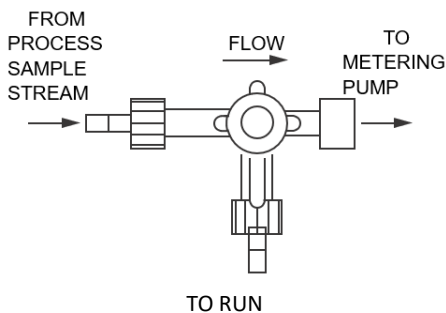

Fig. 3 3-way inlet valve

7.4.2.4 DEOX/2000® BIAS calibration

In performing the BIAS calibration, the slope is calibrated by directly measuring the residual "bias" resulting from the reagents (iodine) added to the cell. This bias can be directly determined only by operating the analyser on zero residual, chlorine demand free water (distilled water), so that the iodine bias residual is the only source of residual. The full procedure is discussed below.

CAUTION

For the BIAS calibration to be accurate the sample water and the distilled water should be at the same temperature.

A full slope calibration of the analyser is generally preformed upon start-up and periodically thereafter.

The nominal Bias value is 1½ times the range of the analyser. Due to variations in feed rate, the actual Bias can vary $\pm 25\%$.

- 1 Place 500 ml of demand free water in a 500 ml flask, and place the flask in the wet side on top of the flow cell. This will cause a small pressure (head) a flooded suction. A 500 ml beaker will not fit.
- 2 Attach two feet of 1/8-inch ID flexible tubing to the calibration leg (middle leg) of the calibration valve. Put the end of the calibration leg (middle leg) tubing of the calibration valve into the flask.
- 3 Move to the BIAS calibration function in the calibration menu of the user interface.
- 4 Move the calibration valve lever to the calibrate position. This closes the valve inlet from the process sample and opens the inlet to the contained sample.

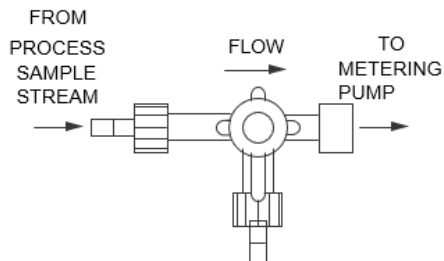

TO RUN

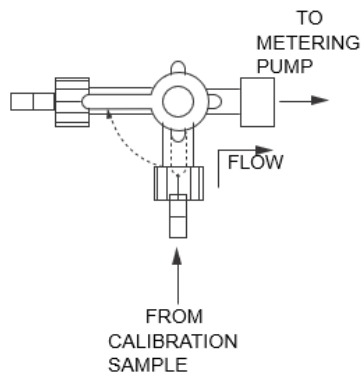

TO CALIBRATE

Fig. 4 3-way inlet valve

- 5 The pump is now drawing sample from the beaker. Allow the sample to purge the pump and cell for five minutes. Wait for the measured concentration to stabilize. Watch the water level in the flask during this period and refill as required. Do not allow the pump to suck in air, as this disrupts the calibration. If this occurs, get out of the calibration procedure and wait for the analyser to stabilize (10-minute delay) before reattempting calibration.

- 6 The screen will display the "BIAS" and "Temp Calibration" on the left and the current bias value and microamp (μA) cell signal on the right. Press the down arrow to access the "Temp Calibration" menu. The cell signal value will be replaced by the current temperature value. If necessary, enter the "Temp Calibration" menu and calibrate the temperature as required.
- 7 Return to the "BIAS" calibration menu. Monitor the microamp cell signal until it stabilizes. The signal will vary by $\pm 5\%$, but will stabilize around a middle point.

NOTICE

The microamp cell signal is dependant on the operating range of the unit, with higher range units having a higher signal strength. Once the signal is stable, enter the desired bias value ($1\frac{1}{2} \times$ range). Return to main display and allow unit to operate on demand free water. Displayed residual should be zero ($\pm 5\%$). Adjust bias as required for zero residual.

- 8 If the calibration is completed before the 10-minute delayed return to operation, the mA is still frozen. The main display continues to function, with a message indicating the delay is in effect.

7.4.2.5 Calibration Tips

The bias calibration method requires that the sample be taken from the cell discharge, where the BIAS produced by the reagents can be directly measured. This sample flow is approximately 16 ml/min. The amperometric titration measurement method requires a 200 ml sample, which requires a sample time of from 12 to 30 minutes. Because of the unstable nature of the iodine residual, particularly in a reactive process, it is not good practice to wait this long to take the sample. If direct measurement of the sample cell residual is desired, it can be done as follows:

- 1 Take a sample of exactly 200 ml (e.g., use a volumetric pipette).
- 2 Dilute it to 200 ml with distilled water in the titration cup. Titrate with 10:1 PAO solution (or, if standard strength PAO is used, multiply the titration value by 10).

7.5 Errors and Remedies

7.5.1 Error Messages

The following table shows and explains all possible error messages which can be displayed. If several errors occur at the same time, the corresponding messages appear alternately in succession. When the error has been remedied, the error message is automatically deleted.

If you are unable to remedy the error yourself, please contact your local Evoqua Water Technologies service department.

Error message	Cause	Remedy
Measured value display flashes	Measured value is outside the measuring range	Check measuring range and change, if necessary. Check dosing or controller settings.
Zero ?	In 3 electrode cells Sensor has zero current > +5 μA or < -5 μA	Electrodes in the 3 electrode cell are soiled; clean and service, if necessary. Sample water is turned off or sample line leaks. Upot potential voltage set incorrectly; change, if necessary.
Calibration ?	In 3 electrode cells Slope error - the sensor current based on 1 mg/l has fallen below the required minimum in measuring range: In measuring range: 10 μA : in. 0.04 $\mu\text{A}/\text{mg}/\text{l}$ 70 μA : in. 0.2 $\mu\text{A}/\text{mg}/\text{l}$ 100 μA : min. 0.4 $\mu\text{A}/\text{mg}/\text{l}$ 200 μA : min. 2 $\mu\text{A}/\text{mg}/\text{l}$ 1000 μA : min. 4 $\mu\text{A}/\text{mg}/\text{l}$	Check whether there are air bubbles on the membrane sensor and remove, if necessary Service membrane sensors - replace electrolyte/membrane cap Clean 3 electrode cells, replace cell sand
Temperature?	Interruption in the temperature sensor or cable	Check multi-sensor and cable
Temp. mod?	Temperature measurement of the sensor measurement module is faulty Interruption in the temperature sensor or cable	Check the temperature sensor and cable
Cell ?	In 3 electrode cells: Chlorine sensor not connected properly No sand cleaning Sensor, sensor cable or sensor module defective Sensor measuring module μA measuring range exceeded	Connect sensor correctly. Check sand cleaning; add if necessary Check the sensor, sensor cable or sensor module, replace if necessary Select higher μA measuring range
Range?	Min/max limit value is outside the measuring range	Check the min/max limit values and change, if necessary
Sample Line Dos	Automatic sample water inlet disinfection	Time-controlled function is ended automatically, as soon as the process is complete

7.5.2 Error

The following table shows and explains possible errors which can occur. If you are unable to remedy the error yourself, please contact the Evoqua Water Technologies service department.

Error	Cause	Remedy
No indication on device	No power supply	External switch or fuse off
	Device fuse defective	Check the power supply and replace fuse
	Housing cover is fitted incorrectly (MFC units only)	Check, fit the housing cover correctly (cable possibly trapped)
Measured value display not available, although the appropriate measuring module is installed	Measuring module defective or fitted incorrectly	Check, refit module correctly, replace measuring module

8 MAINTENANCE

8.1 Maintenance Schedules

The following maintenance schedules are recommendations only. Adhere to the appropriate standards, regulations and locally applicable guidelines.

Task	Period/Interval
MICRO/2000® and DEOX/2000® flow block assembly	
Check for leakages	Weekly
Comparative measurement, calibrate if necessary	Weekly/acc. to guidelines
Check electrolyte level (MICRO/2000® and DEOX/2000®)	Weekly
Check cell sand (MICRO/2000® and DEOX/2000®)	Weekly
Change cell sand (MICRO/2000® and DEOX/2000®)	Every six months
Change electrolyte (MICRO/2000® and DEOX/2000®)	Every six months
Change porous element (MICRO/2000® and DEOX/2000®)	Every six months (depending on water quality)
Replace the impeller shaft and shaft seal	Yearly

8.1.1 Check for tightness

Check the entire measuring device including all screw connections for leakage. Repair any leakage points immediately.

NOTICE

Air bubbles in the sample water influence the measuring accuracy. The cause must be determined and remedied.

8.1.2 Checking the cell sand

Check that there is sufficient sand in the cell body. The cell sand must be swirled around in the bottom section of the cell body. The cell sand is necessary for cleaning the chlorine sensor electrodes and must be replenished or replaced when required. (Refer to section 5.4.2 "Pour in the cell sand (only with MICRO/2000® and DEOX/2000®)" and "Changing cell sand with 3-electrode cell MICRO/2000® and DEOX/2000®".)

NOTICE

When fresh sand is replenished, the electrode current may increase slightly for approximately 3 hours. Do not calibrate during this time. You must calibrate each time the cell sand is replaced. The calibration must be checked after one day.

8.2 Maintaining MICRO/2000® and DEOX/2000® Flow Block Assembly

WARNING

To avoid electrical shock, turn off power before servicing.

WARNING

To avoid electrical shock or damage to equipment, avoid contact with circuit board components while making adjustments.

WARNING

Wear recommended protective eyewear when servicing the wet components of the analyser, particularly when servicing reagents and reagent lines. The analyser uses chemicals that can cause severe personal injury by chemical burns on contact with eyes. Rinse any area of contact immediately. If chemicals contact eyes, rinse from eyes and seek immediate medical attention.

8.2.1 Wetside panel removal and replacement

- 1 Shut off sample flow to the analyser.
- 2 Disconnect the probe and motor connectors from the SFC electronics, if those parts will be serviced.
- 3 Remove the probe and set it carefully aside. Do not rest it on its electrode end. If the probe will be removed for more than an hour, place it, with the electrodes, in a beaker of water.
- 4 Disconnect the liquid reagent tubing from the inlet and discharge of the metering pump.

- 5 Disconnect the water sample tube from the panel inlet.
- 6 Disconnect the drain tubing from drip tray outlet.
- 7 Remove the clamps holding the probe cable, if probe will be serviced.
- 8 Remove the four screws holding the panel in the enclosure, and remove the panel from the enclosure. The panel will hang in front of the enclosure on strain relief cables.
- 9 Hold the panel upright while removing it to avoid spilling water trapped in the cell. Remove mounting screws and set aside before releasing panel. There is water trapped in the various tubing units and chemical trapped in the reagent tube units.

8.2.2 Occlusion ring removal and replacement

WARNING

To avoid possible severe personal injury or equipment damage, observe the following:

- Turn off the flow to the analyser before removing the occlusion ring from the metering pump. The occlusion ring stops the free flow of liquid through the analyser sample lines. If it is removed with flow still present at the analyser, process water will be sprayed from the pump discharge line and from the cell top. Sprayed process water can create an electrical shock hazard due to the presence of dangerous voltage powering the impeller and pump motors.
- Do not service the metering pump while it is turning, the metering pump has enough torque to cause severe personal injury if hands are pinched in the rotating parts. Disconnect the pump motor POWER before servicing the pump.
- Wear recommended protective eye-wear when servicing the wet components of the analyser, particularly when servicing reagents and reagent lines. The analyser uses chemicals that can cause severe personal injury by chemical burns on contact with eyes. Rinse any area of contact immediately. If chemicals contact eyes, rinse from eyes and seek immediate medical attention.

8.2.2.1 Removal

- 1 Disconnect power to the wet side of the analyser by disconnecting the power supply from the SFC electronics.
- 2 Turn off the water supply to the analyser.
- 3 Remove the wet side panel (optional). See paragraph 8.2.1, "Wet Side Panel Removal and Replacement".
- 4 Using a 7/16-inch socket wrench, remove the two bolts (with washers) attaching the occlusion ring to the panel. Lift off the occlusion ring. Some residue from the tube units accumulates on the ring during usage. This is normal.

8.2.2.2 Replacement

The occlusion ring may be difficult to reinstall if the following procedure is not followed. Do not use excessive force. Use care not to pinch the tube units (installed on the pump rollers) when installing the occlusion ring. Before reinstalling the occlusion ring, check that the pump tube units are properly seated in the roller grooves and in the tube retainer grooves. See paragraph 8.2.4, "Pump Tubing Units Replacement".

- 1 Place the occlusion ring loosely in place over the tube units, but do not attempt to clamp the occlusion ring in place yet.
- 2 Hold the ring in place with one hand and slide a bolt, with washer, into the lower mounting hole in the ring until it bottoms against the casting.
- 3 Gently squeeze the ring against the tubing while pushing the bolt into place. The bolt will drop (about ¼ inch) into place when the ring is properly located.
- 4 Tighten this first bolt a few turns, so that the occlusion ring will pivot on the bolt.
- 5 Slide the second bolt (and washer) into its mounting hole in the ring.
- 6 Firmly squeeze the ring against the pump rotor (squeeze near the second bolt) to obtain leverage against the pivot bolt until the second bolt drops into place. Finger tighten bolts until occlusion ring is flat against panel.
- 7 Tighten bottom bolt 1/4 turn, then tighten top bolt 1/4 turn.

8.2.3 Pump rotor, rollers and thrust washer removal and replacement

The rotor is fastened to the motor shaft by a set screw requiring a 3/32-inch Allen wrench for adjustment.

When the rotor body is removed, check the rollers, roller shafts, thrust washer, the shaft bearing, and shaft bore in the rotor body for signs of excessive wear, damage, or corrosion. Some residue on the roller shafts and inside the rollers is normal. The rotors should function properly for at least one to two years. Do not lubricate the rollers, as some greases may attack the nylon roller material. Lubrication of the rollers is not necessary. If any of the roller shafts show significant wear marks and the corresponding roller is loose, the rollers and rotor body unit must be replaced.

8.2.3.1 Removal

- 1 Remove the wet side panel from the enclosure, see section Figure 8.2.1.
- 2 Remove the occlusion ring from the panel unit.
- 3 Remove the sample and reagent tube units from the metering pump.
- 4 Locate the set screw in the hub of the rotor body (just behind the back face of the body) and loosen the set screw one or two turns.

NOTICE

Hold the panel upright while removing the rotor body to avoid dropping and losing the rollers. To use as a guide for reinstallation, take note of the orientation of the rollers (small groove toward the front of the panel) before removing the rotor.

- 5 Slide the rotor body off the motor shaft.
- 6 The thrust washer (located against the panel assembly) should be removed and set aside so that it does not drop off the panel and become lost.

8.2.3.2 Reinstallation

- 1 If the thrust washer was removed, reinstall it over the pump hub, against the panel.
- 2 Install the rollers on their shafts in the position noted during the removal of the rotor (small groove toward front).
- 3 Look into the shaft bore in the rotor body and adjust the set screw until it just pro-

trudes into the bore (approximately a half turn). The set screw protruding into the bore helps to locate it on the flat of the shaft as the rotor assembly is installed.

- 4 Note the position of the flat on the pump shaft and slide the rotor assembly onto the shaft with the set screw over the flat.
- 5 The shaft bore has a sliding fit on the shaft, so there may be a slight resistance to the sliding. If the resistance seems excessive, back-off the set screw a quarter turn and twist the rotor body back and forth slightly as it slides back onto the shaft.
- 6 Tighten the set screw gently, until it begins to lock in place, on the flat on the shaft. Be sure that the hub of the rotor is flush against the pump hub (but without pressure) when the set screw is tightened. Using the Allen wrench, tighten the set screw as firmly as is practical. Use pliers to apply additional torque, but not so much as to permanently deform the Allen wrench.

NOTICE

If the set screw is not tightened sufficiently, the rotor may wobble on the shaft or may slip on the shaft, damaging the shaft and causing the pump to not operate properly.

8.2.4 Pump tubing units replacement

WARNING

- Turn off the flow to the analyser before removing the occlusion ring from the metering pump. The occlusion ring stops the free flow of liquid through the analyser sample lines. If it is removed with flow still present at the analyser, process water will be sprayed from the pump discharge line and from the cell top. Sprayed process water can create an electrical shock hazard due to the presence of dangerous voltage powering the impeller and pump motors.
- Do not service the metering pump while it is turning, the metering pump has sufficient torque to cause severe personal injury if hands are pinched in the rotating parts. Disconnect the pump motor connector before servicing the pump.
- Wear recommended protective eyewear when servicing the wet components of the analyser, particularly when servicing reagents and reagent lines. The analyser uses chemicals that can cause severe personal injury by chemical burns on contact with eyes. Rinse any area of contact immediately. If chemicals contact eyes, rinse from eyes and seek immediate medical attention.
- The sample and reagent tube units include glued stop rings and adapters and fittings. Replace the entire unit when required.
- The tube units should provide approximately six months of service, but should be observed monthly (without disturbing the analyser) for signs of wear or leakage. If either condition is noticed, replace the suspected tube units immediately.

Remove the tube units only when replacement units are readily available, so there is no confusion about how to reconnect the new tube units.

- **Removal of the tube segments is as follows:**

- 1 Disconnect power to the wet side.
- 2 Disconnect the sample and reagent tubing from the fittings at the ends of the tubing segments. The fittings are replaced with the tube units.
- 3 Remove the occlusion ring mounting bolts (requires a 7/16-inch socket).
- 4 Remove the tube units.

- **Installation of tube units (refer to Figure 1):**

- 1 Remove the occlusion ring (A).
- 2 Remove the old tube units (B or C) (if replacing).
- 3 Both reagent tube units (C) fit into the small groove (D) on the tube retainer (F), as well as into the small groove (H) on the rollers (G).
The sample tube unit (B) fits into the large groove (E) on the tube retainer (F) and the large groove (I) on the rollers (G).

Guide the (new) tube unit through the small (D) or large (E) groove in the lower end of the tube retainer (F) and slide the unit up through the groove until the lower tube stop (J) is against the outer surface of the tube retainer (F).

- 4 Lay the tube unit (A or B) over the pump rollers (G) in the small (H) or large (I) groove, toward the front of the pump rollers. If two reagent tube units (C) are installed, ensure that the tubes lay side by side and do not cross each other when placed over the rollers (G).

- 5 Stretch the tubing slightly and guide it through the small (D) or large (E) groove in the upper end of the tube retainer (F), with the upper tube stop (K) above the top surface of the upper end of the tube retainer (F). When tension on the tubing is released, the tube stops should be against the outside surfaces of tube retainer.
- 6 Check that the tube units (B or C) are in their proper small (H) or large (I) groove in the roller (G). Check that the reagent tubes do not cross.
- 7 Replace the occlusion ring, so that the larger inside radius (in which the sample tubing (B) rides) is facing away from the operator. Locate and start the lower mounting bolt before attempting to squeeze the occlusion ring against the tubing. Then secure the second mounting bolt.

The tubing exerts side pressure on the retaining bolts, causing some tendency for cross-threading of the bolts as they are reinstalled. Do not force the bolts. If they do not turn smoothly, remove them and install them again.

NOTICE

If the pump is operated with the reagent tube units crossed, the tube units may be damaged.

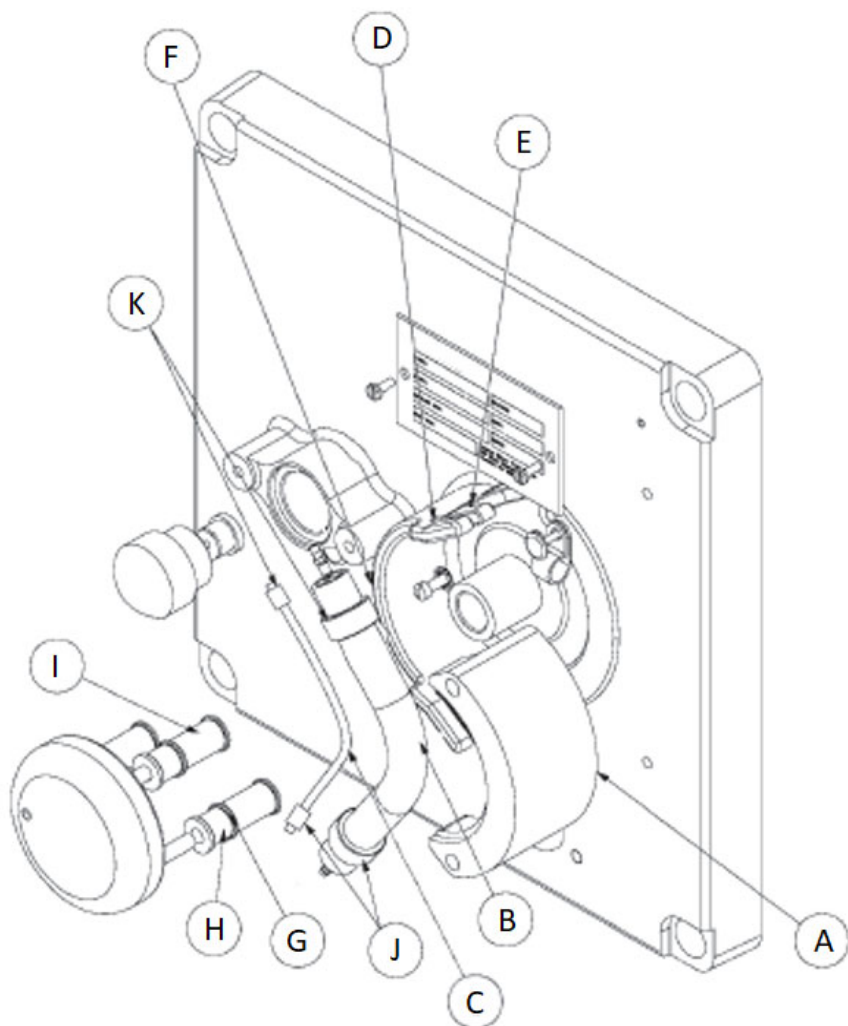

Fig. 1 Installation of tube units

- A Occlusion ring
- B Sample tube
- C Reagent tube
- D Reagent groove
- E Sample groove
- F Retainer surface
- G Sample segment - roller
- H Reagent segment - roller
- I Roller
- J Tube retaining collar
- K Tubing connector

8.2.5 Pump bearing replacement

- 1 Remove the wetside panel from the mounting enclosure.
- 2 Remove the pump occlusion ring, tube units, rotor body (with rollers), and thrust washer from the front of the wetside panel.
- 3 Remove the pump motor from the rear of the wetside panel. The pump mounting screws are on the face of the panel.
- 4 Drive the bearing out of the front of the casting using the square end of a rod that is approximately ½-inch in diameter by 4 inches long. (A socket wrench socket on an extension will work.) Use care not to scar the bore in which the bearing is pressed.
- 5 Tap in the new bearing until it is flush with the end of the bearing support. Place the long side of a flat bladed screwdriver over the bearing face and tap with a hammer. Make sure the new bearing is square to the bearing support bore.

8.2.6 Impeller shaft seal replacement

8.2.6.1 Removal of the Impeller Shaft Seal

- 1 Disconnect power to the wetside of the analyser.
- 2 Remove the probe from the cell body. Make sure the probe electrodes are not scratched or damaged. Lay the probe on its side so that the electrodes do not contact any surface, but in a position so that the electrolyte does not leak from reservoir fill hole.
- 3 Remove the cell body retaining screws and remove the cell body. When removing the cell body take notice of the O-ring that seals the cell body against the seal adapter. This O-ring may cling to the cell body and then fall off.
- 4 Use a 3/32-inch Allen wrench to loosen the set screw holding the impeller on the shaft. This set screw leaves a noticeable mark on the shaft. If the shaft is not replaced, reinstall the impeller in the same position.
- 5 Slide the grit guard off the shaft.
- 6 Slide the seal adapter, with the seal and impeller shaft bearing, off the shaft.

- 7 Using a pair of needle nose pliers, grab the center of the seal and remove it from the front of the adapter.
- 8 Using a nut driver or small socket and extension, press the impeller shaft bearing out of the seal adapter from the front.
- 9 Rinse the grit from the cell body, cell body sealing O-ring, impeller, and seal adapter. Wipe the sealing surfaces and the shaft (gently) with a paper towel to remove all grit and residue.
- 10 Check the shaft for signs of unusual wear, which indicates that it needs replacement. Refer to Impeller Shaft Replacement instructions.

8.2.6.2 Installation of shaft seal

- 1 If not already done while removing old shaft seal, rinse grit from the cell body, cell body sealing O-ring, impeller, and seal adapter. Wipe the sealing surfaces and the shaft (gently) with a paper towel to remove all grit and residue.
- 2 Press new impeller shaft bearing into back of seal adapter. Apply a small quantity of silicone grease to front and back bearing shaft hole.
- 3 Apply a small quantity of silicone grease to the back side (the frontside is the concave side) of the new U-cup before installation into the seal adapter.
- 4 Install the U-cup into the seal adapter, making sure the edges are fully seated (flush with the inside diameter of the seal adapter).
- 5 Slide the seal adapter over the impeller shaft until it seats in the panel. Wipe any excess grease from the front of the shaft.
- 6 Slide the grit guard (small end first) onto the shaft and up against the seal adapter.
- 7 Slide the impeller onto the shaft, up to the grit guard. Retighten the set screw until just snug.
- 8 Install the cell body sealing O-ring on the front of the seal adapter.
- 9 Install the cell body with the retaining screws and washers.
- 10 Replace the probe.
- 11 Restart the analyser.
- 12 Once the flow is restarted and the cell body is full of sample, replace the grit.

8.2.7 Impeller motor removal and replacement

8.2.7.1 Removal

- 1 Remove the panel assembly from the mounting enclosure. See paragraph 8.2.1, "Wetside Panel Removal and Replacement".
- 2 Remove the cell body, impeller, and shaft seal adapter from the front of the panel assembly. See paragraph 8.2.6, "Impeller Shaft Seal Replacement".
- 3 Turn the panel over and remove the ground lug screw and motor mounting screws.
- 4 Remove the motor with the impeller shaft.
- 5 If the motor is being replaced, remove the impeller shaft and coupling from the motor.

8.2.7.2 Replacement

Replacement is basically the reverse sequence of removal.

Grease the impeller shaft seal, with suitable silicone grease, before reinstalling it on the front of the panel assembly.

WARNING

- Always reconnect the grounding leads when removed or broken. Grounding leads are provided for safety, to prevent injury from electrical shock.
- Be sure to reconnect both motor ground leads to the back of the panel before reinstalling the panel.
- Motor replacement is the reverse sequence of removal.

8.2.8 Impeller shaft replacement

8.2.8.1 Impeller Shaft Removal

- 1 Disconnect power to the wetside of the analyser.
- 2 Stop the flow of sample to the analyser.
- 3 Disconnect the sample and reagent tubing from the metering pump inlet.
- 4 Remove the cell body, impeller, grit guard, cell sealing O-ring, and seal adapter as described in paragraph 8.2.6, "Impeller Shaft Seal Replacement".
- 5 Remove the panel assembly from the mounting enclosure.
- 6 Disconnect the impeller motor grounding terminal.
- 7 Remove the impeller motor mounting screws and washers. Remove the impeller motor.
- 8 Loosen the impeller shaft retaining set-screw using a 3/32-inch Allen wrench.
- 9 Remove the impeller shaft from the coupling.

8.2.8.2 Impeller Shaft Installation

- 1 If the impeller shaft coupling is removed from the impeller motor install the coupling on the motor shaft against the front face of the motor. Tighten the retaining setscrew (using a 3/32-inch Allen wrench).
- 2 Slide the impeller shaft into the coupling until it bottoms against the end of the motor shaft. Tighten the retaining setscrew snugly (using a 3/32-inch Allen wrench), about ¼ turn past the first resistance.
- 3 Mount the impeller motor on the back of the panel with the retaining screws and washers.
- 4 Fasten the impeller motor grounding terminal (with pump motor grounding terminal) on the back of the panel with the retaining screw and serrated lockwasher.
- 5 Remount the panel in the mounting enclosure.
- 6 Reattach the sample and reagent tubing to the inlet of the metering pump.
- 7 Apply a small quantity of silicone grease to the O-ring and impeller shaft.
- 8 Reinstall the seal adapter, grit guard, cell sealing O-ring, impeller, and cell body and cell retaining screws, as described in paragraph 8.2.6, "Impeller Shaft Seal Replacement"- Installation of Shaft Seal.

8.2.9 Pump motor removal and replacement

- 1 Remove the panel assembly from the mounting enclosure. Refer to paragraph 8.2.1, „Wetside Panel Removal and Replacement“.
- 2 Remove the pump rotor and thrust washer from the panel assembly. Refer to paragraph 8.2.1, „Pump Rotor, Rollers, and Thrust Washer Removal and Replacement“.
- 3 Disconnect the motor ground lead from the back of the panel.
- 4 Remove the two screws that mount the motor from the front of the panel.
- 5 Gently slide the motor out from the back of the panel. The motor shaft has a sliding fit inside the ball bearing in the pump hub. If it binds while trying to slide it out, check the exposed portion of the shaft for dirt or scratches that may cause binding. Clean off the dirt or carefully remove scratches with a fine file. The shaft can be damaged by excessive filing.

NOTICE

Motor W2T416878 and W2T416877, key no. 36 of BOM on page 61, are wear parts having a service life of only one and a half upto two years.

8.2.10 Probe electrolyte and electrodes

The analyser performs best when the probe is left undisturbed as much as possible. Manual cleaning of the probe electrodes should not be done unless necessary, as this will require recalibration of the analyser.

CAUTION

Do not sand the probe electrodes! The electrodes are made of a thin film of platinum and cannot be replaced or repaired. If sanded, this thin film of platinum will be quickly removed and the probe will no longer function. If cleaning is necessary, a clean paper towel may be used.

Check the electrolyte level occasionally and maintain the level so that it is at least visible through the clear section of the probe with the probe in the installed position. If the electrolyte level drops noticeably in less than a month, the porous element is leaking excessively. The porous element is intended to allow a slight flow of electrolyte and excessive flow will not harm the performance of the analyser unless the probe is allowed to run out of electrolyte. If excessive use of electrolyte becomes a nuisance (requires constant monitoring of the level), replace the porous element and check the element bore for damage that would hinder the sealing around the element.

Also, check if the electrolyte has become contaminated. This is usually indicated by a color change or by the electrolyte becoming watery. It is not unusual for the electrolyte to become alternately cloudy and then clear, this can be caused by changes in water or ambient temperature.

8.2.11 Probe cleaning, refilling and porous element replacement

The probe cannot be disassembled (all joints are cemented). It is not serviceable except for the following maintenance operations.

NOTICE

The analyser will perform best when the probe is left undisturbed as much as possible.

Check the electrolyte level and refill as necessary.

Clean the electrodes by wiping blue abrasive paper or with a clean paper towel. If there is a greasy film on the electrodes, this can be removed by cleaning with a paper towel dipped in alcohol. If there are hard deposits on the electrodes, this can be removed by wiping the electrodes with a clean paper towel dipped in muriatic acid (10% hydrochloric acid). The analyser will require recalibrations after 24 hours of operation after the electrodes are cleaned.



WARNING

Hydrochloric acid and muriatic acid will severely irritate eyes and cause chemical burns to skin. Always wear appropriate protective equipment during handling. When diluting acid, always pour acid into the water, never pour water into acid. It is the responsibility of the user of the equipment to obtain and follow the safety precautions of the manufacturer of the hazardous material.

If the probe is to be stored for more than a week, the porous element should be removed, the electrolyte drained, and the reservoir should be rinsed with distilled water to eliminate any remaining electrolyte. Otherwise the electrode end must be kept wetted to prevent crystallization of the electrolyte in the pores of the element and clogging of the element.

The porous element can be removed and the electrolyte drained as follows: Using a self-tapping screw (a #6 drywall screw is preferred), tap into the porous element, then pull out the element. The element is approximately 6mm (¼-inch) long. This porous element is no longer usable. The electrolyte will drain out slowly. Rinse the reservoir well with distilled water to remove residual electrolyte. When removing the element in this manner, use care not to scar the sides of the element bore as this might prevent insertion of a new piece of porous material or cause excessive leakage of the electrolyte.

A new porous element can be created and installed as follows: Do not pre-cut the porous material to length. A clean, sharp razor blade is required to make a clean cut in the porous material. First, using a sawing motion, slice off a thin slice of one end of a length of the porous material. Press this fresh cut end into the element bore. The fit should be snug. The material should be embedded to a 6 to 9mm (¼" to 3/8") depth. Cut off protruding portion of porous element flush with probe tip, being very careful not to scratch or damage electrodes.

9 Illustrations

MICRO/2000® AND DEOX/2000® CE WETSID E ENCLOSURE ASSEMBLY - PARTS - W3T140748 (240V) - W3T332446 (115V)

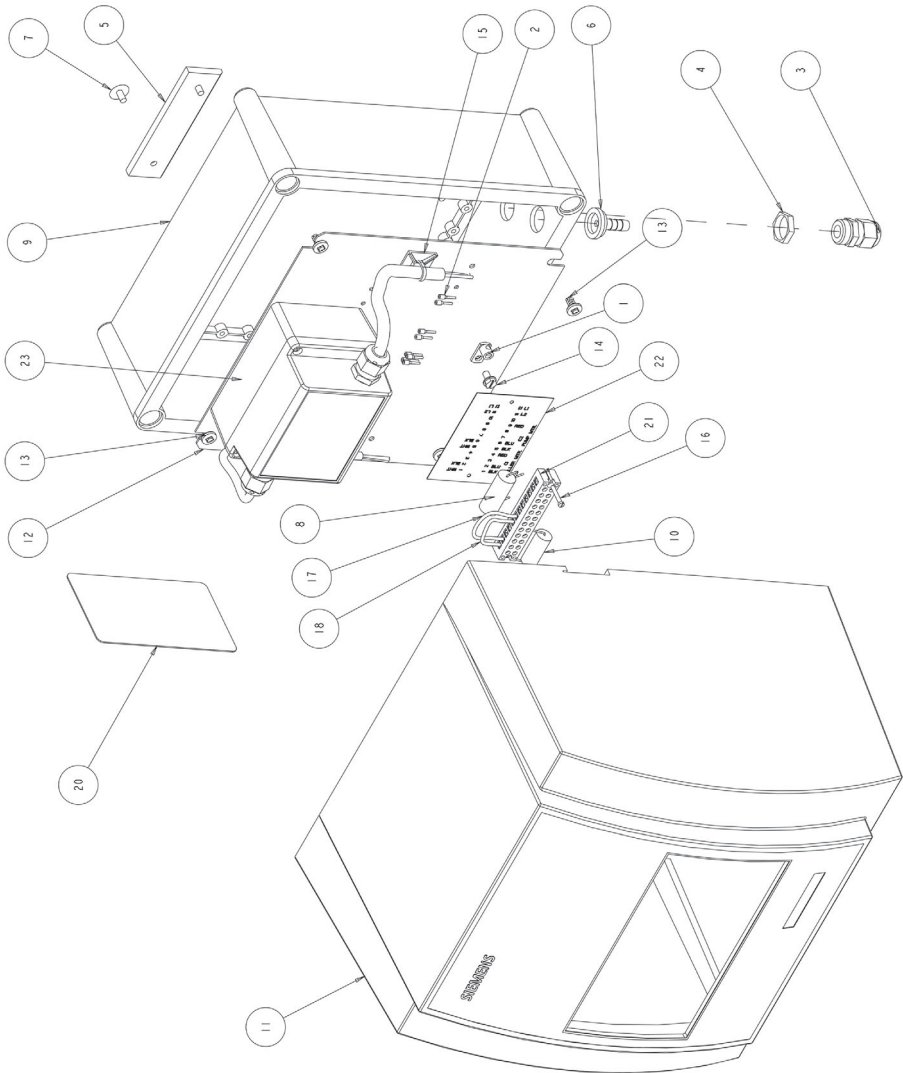

Fig. 1 50.580.000.035A - ISSUE 2 7-14

MICRO/2000® AND DEOX/2000® CE WETSID E ENCLOSURE ASSEMBLY - PARTS LIST - W3T140748 (240V) - W3T332446 (115V)

KEY	PART NO.	QTY.	DESCRIPTION
1	W2T1535	1	Grounding lug
2	W2T504179	8	Bootlace ferrule, insulated, 1.5Mm
3	W3T160551	1	M20 cable gland
4	W2T416769	1	Cable gland nut
5	W2T416873	2	Din rail guide
6	W2T365250	1	1/4" Flat seat hose barb
7	W2T365251	4	Rivet
8	W2T416875	1	Capacitor, 15 μ f \pm 20x, 100v
9	W2T416879	1	Enclosure mach'd
10	W2T416880	1	Capacitor, 10 μ f \pm 20x, 100v
11	W2T416881	1	Facade, complete
12	W2T416882	1	Mach'd mounting plate
13	W2T365269	4	Mounting plate screw
14	W2T365269	1	10-32 Unc x 3/8 green ground screw 15
15	W2T366020	2	Mb3a10c2, cable mounts
16	W2T19230	2	Terminal block mounting screw
17	W2T375930	1	18 Awg stranded wire, black
18	W2T16189	1	18 Awg stranded wire, white
19	W2T19887	1	Shrink tubing, 0.46 Id bs
20	W2T11555	1	Warning label
21	W2T13305	1	Terminal block, captive wire
22	W2T421097	1	Strip, marker
23	W3T139780	1	Enclosure assembly, ce transformer

NOTICE

When ordering material always specify model and serial number of apparatus.

**MICRO/2000® AND DEOX/2000® WETSID E CASTING ASSEMBLY - PARTS -
W3T140748 (240V) - W3T332446 (115V)**

Fig. 2 50.580.000.040B - ISSUE 3 7-14

MICRO/2000® AND DEOX/2000® WETSID CASTING ASSEMBLY - PARTS - W3T140748 (240V) - W3T332446 (115V)

KEY	PART NO.	QTY.	DESCRIPTION
1	W2T8855	1	Seal, adapter, pvc
2	W3T172188	1	Label, warning
3	W2T416867	1	Casting, al6061
4	W2T416872	1	Drip trough, pvc
5	W3T108352	1	Name tag
6	W2T416876	1	Motor, reversible, 600/500 rpm
7	W2T17575	2	Screw, #8-32 x 1/2" lg.
8	W2T375790	2	Bolt, 1/4-20 x 2-1/4" lg.
9	W2T19395	3	Set screw, #6-32 x 3/16" lg.
10	W2T17709	2	Ring terminal, blue
11	W2T17365	3	Clamp, plastic
12	W2T17476	2	Screw, #10-32 x 1/2" lg.
13	W2T376054	2	Screw, 1/4-20 x 1-1/4" lg.
14	W2T18721	2	Lockwasher, #8 internal type
15	W2T18998	2	Lockwasher, #6 internal type
16	W2T19844	4	Screw, #6-32 x 3/8" lg.
17	W2T15636	4	Lockwasher, 1/4"
18	W2T14421	2	Screw, #10-24 x 3/4" lg.
19	W2T13299	3	Clip, plastic
20	W2T12538	1	Bearing, pvc
21	W2T12112	1	U-cup, teflon
22	W2T418119	1	Seal, grit, teflon
23	W2T11682	1	Coupling, brass
24	W2T11674	1	Occlusion ring, teflon
25	W2T11675	1	Thrust washer, teflon
26	W2T11676	3	Pump roller, nylon
27	W2T11678	1	Impeller shaft, polyethylene
28	W2T376256	1	Impeller, pvc
29	W2T11680	1	Cell, e 796 tyril
30	W2T376260	1	Set screw, ss, #10-24 x 1/2" lg.
31	W2T376750	1	O-ring, (O18), epr
32	W3T107925	1	Rotor body unit, steel
33	W3T107926	1	Tube unit, assembled
34	W2T11687	1	Ball bearing, steel, 1/4" id x 5/8" od
35	W2T291156	1	Label, notice
36	W2T416877	1	Motor, 1 rpm
	W2T416878	1	Motor, 2 rpm (used in W3T980557, W3T98058 AND W3T98057)

NOTICE

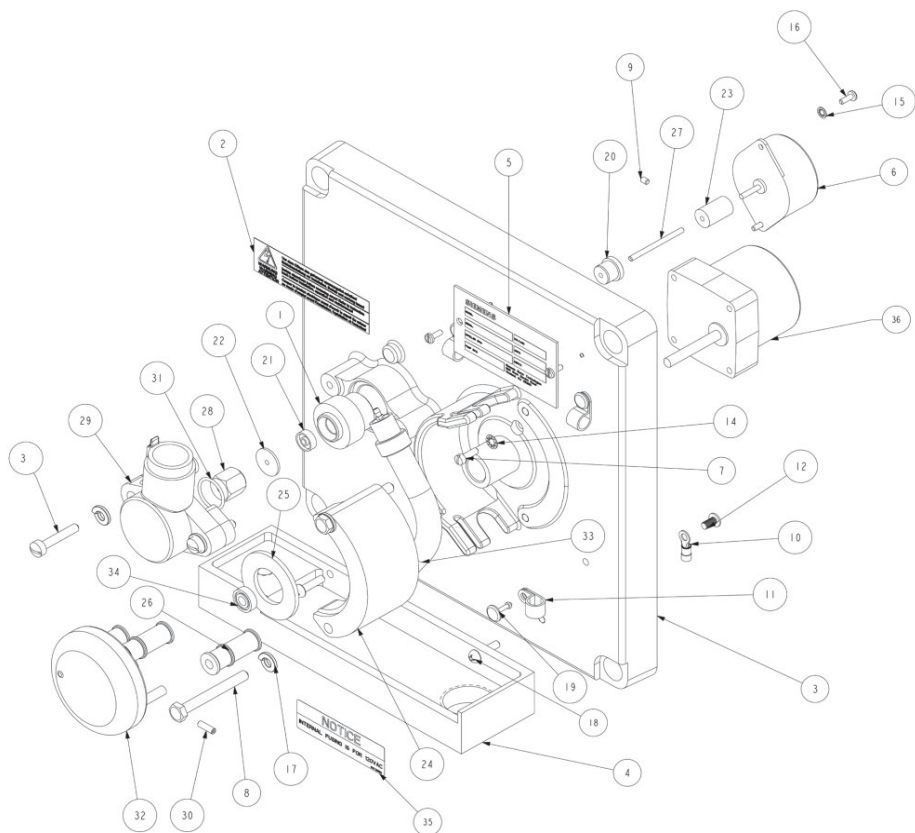
When ordering material always specify model and serial number of apparatus.

Motor W2T416878 and W2T416877, key no. 36, are wear parts having a service life of only one and a half upto two years.

MICRO CE - DEOX 2000 WETSIDE

FUNCTIONAL TESTS

After verifying the wiring is correct, connect power. Verify that the pump and impeller operate smoothly and quietly (indicating no mechanical problems). Both motors should be turning counter-clockwise.

NOTE: It is sufficient to note that the impeller appears to be turning rapidly. The pump motor will turn at 2 RPM.

NOTE: Break the bypass line from the 1/2" sensor on module mounted arrangements to reduce water flow. Connect (cold) water supply to the analyzer inlet. Water supply should be set to 0.2 (0.05) L/min. Connect request tubing to the inlet receiver flange of the pump and place the end of the tubing length (about 1.2m (4 feet)) in a reservoir of water (at least 600 mm (2 feet) below the analyzer to test the priming capability).

Allow time for the pump to prime and request tubing to prime. Inspect on priming and tubing for leaks.

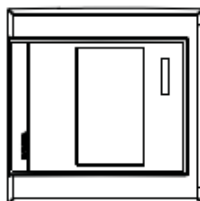

W01419981 (A402385)
LISTED UNDER W01461743

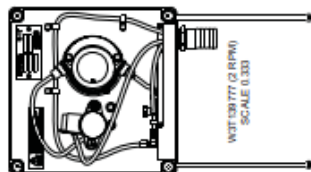

W01031777 (2 RPN)
SCALE 0.333

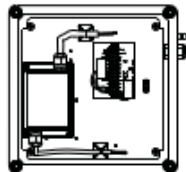

W01461743

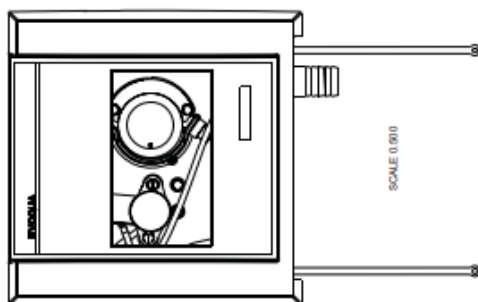
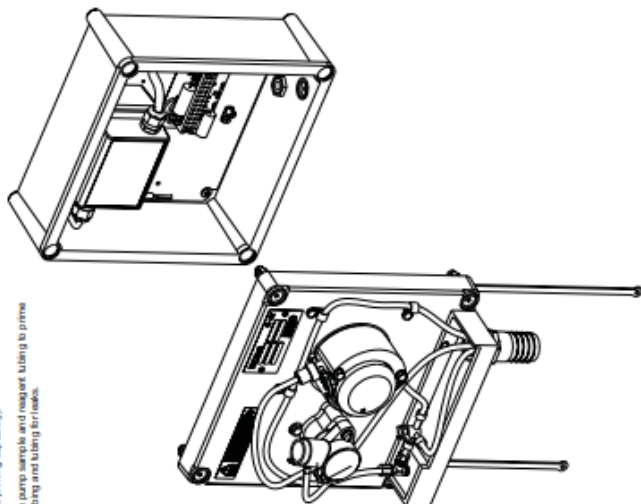

SCALE 0.0010

Fig. 3 GAA1177 sheet 2 - issue 6

W3T108351 WATERLINE KIT - PARTS LIST

KEY	PART NO.	QTY.	DESCRIPTION
1	W2T19400	1	Reducing bushing, pvc, 1/4" x 1/2" npt
2	W2T16766	1	Nipple, pvc, 1/4" x 1/4"
3	W2T19799	1	Nipple, pvc, 1/2"
4	W2T14737	2	Elbow, pvc, 90°
5	W2T12055	2	Union nut, pvc, 1/2-20 thread
6	W2T16217	1	Tubing, polyethylene, 1/4" id, 3 ft
7	W2T15468	1	Valve, cci pvc
8	W2T13310	1	Y strainer, pvc
9	W2T12996	1	Labcock valve, pvc/epdm, 1/4" t x t
10	W2T378415	1	Ball valve, 1/2" single entry, pvc type

NOTICE

When ordering material always specify model and serial number of apparatus.

W3T108351 WATERLINE KIT

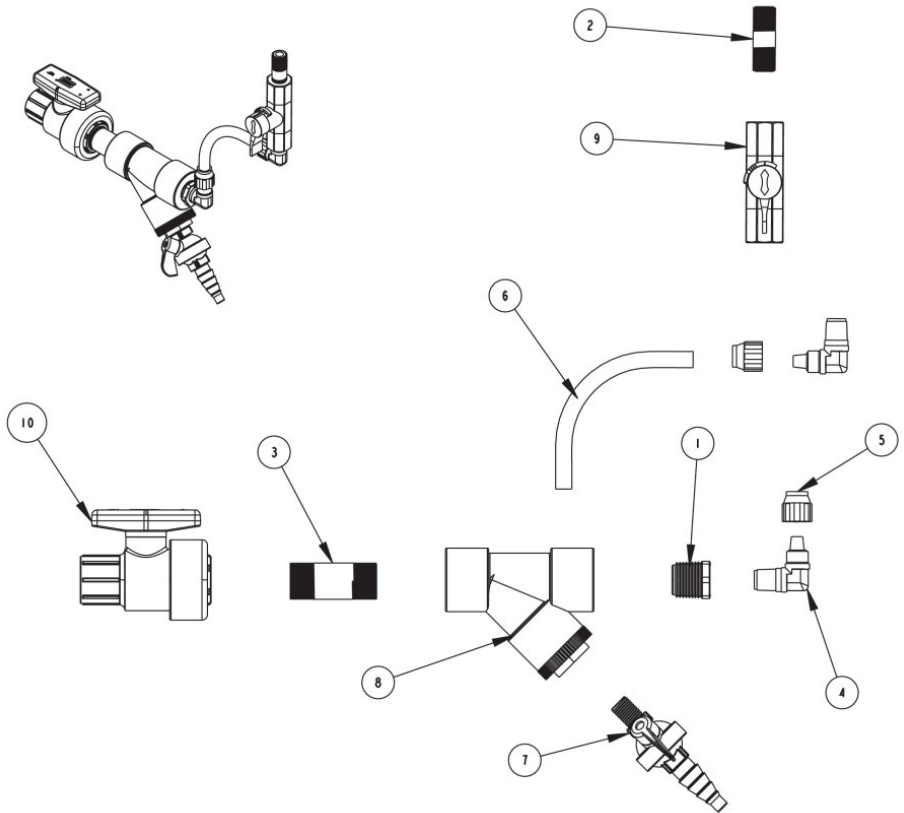

Fig. 5 50.580.000.050B - ISSUE 1 9-10

W3T8601 REAGENT - PARTS

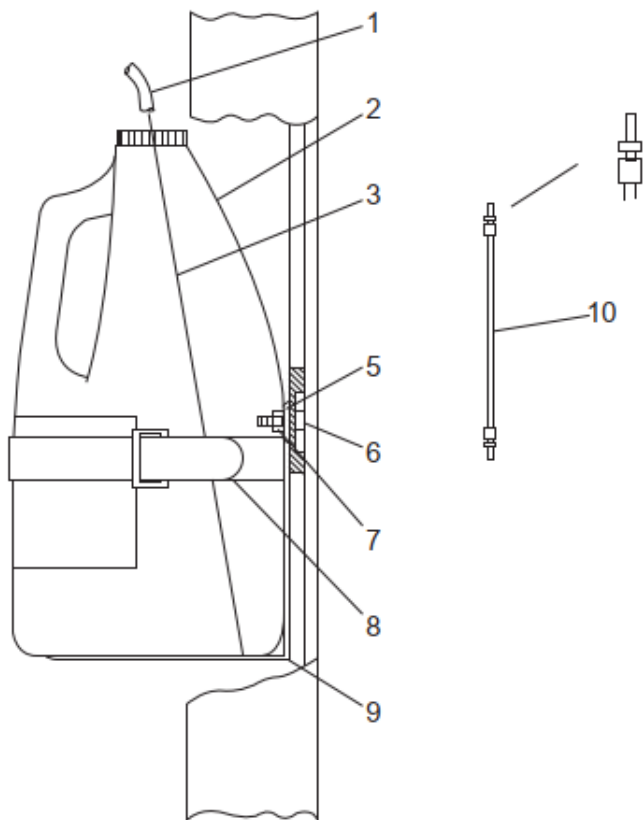

Fig. 6 50.505.020.010 - ISSUE 4 9-03

KEY	PART NO.	QTY.	DESCRIPTION
1	*W2T11685	8	Tubing (.020 ID) norprene
2	W3T110057	1	Bottle
3	W2T11234	1	Rigid tubing (.027 ID), 13" lg.
5	W2T16958	2	1/4" lockwasher (SS)
6	W2T18825	2	Mach. Screw (rd.Hd.,SS) 1/4"-20 x 3/4" lg.
7	W2T417965	2	Hex. jam nut (SS) 1/4"-20
8	W2T14861	1	Strap
9	W2T13382	1	Bottom bracket shelf
10	W3T107927	1	Reagent tube unit

NOTICE

NOTE: *Not part of W3T98601.

When ordering material always specify model and serial number of apparatus.

10 COMPLETE DEVICES , RETRO FIT KITS & SPARE PARTS

10.1 Retrofit Sets

10.1.1 3-electrode cell MICRO/2000® with P T1000

Part No.	Description
W3T158828	Plug-in card with terminals
W3T158830	With optional Process Control

10.1.2 3-electrode cell DEOX/2000® with P T1000

Part No.	Description
W3T158829	Plug-in card with terminals
W3T158831	With optional Process Control

10.2 MICRO/2000® and DEOX/2000® Spare Parts and Consumables

Part No.	Description
W3T100141	Electrode cleaning sand
W3T165565	Electrolyte set
W2T12276	Probe porous junction material
W3T99781	Probe: Std. range
W3T99785	Probe: High range

10.3 MICRO/2000® and DEOX/2000® Spare Parts List

Part No.	Qty.	Description
W3T107488	1	Preventive maintenance kit
W3T107926	*1	Sample tube assembly (Sample metering pump)
W3T107927	*2	Reagent tube assembly (Sample metering pump)
U10242	*1	Tube silicone grease (for impeller shaft seal)
W2T12538	*1	Bearing
W2T12112	*1	Impeller shaft seal
W2T11678	*1	Impeller shaft
W2T12113	*1	Fit guard, Impeller shaft
W2T376750	*1	O-ring (For cell, size #018, EPDM)
W2T11683	16 Ft	Reagent tubing (yellow, 5/32" OD, Norprene)
W2T12617	4 Ft	Sample tubing (black, 1/4" OD, Norprene)
W2T12016	2 Ft	Sample tubing (translucent, 1/4" OD, LDPE)
W3T100141	1	Tube Tube grit
W2T12276	6 in.	Probe junction material
W3T165565	1 Btl	Probe electrolyte solution, 2 oz.
W2T416885	1	Fuse, 3 AG 1/4 Amp, 250 VAC
W2T416886	1	Fuse, 3 AG 1/2 Amp, 250 VAC
W3T108269	1	Abrasive paper (1" x 2")
W3T122322	1 m	DIN rail (39.37")
W2T492188	2	Fuse, 5 x 20mm, 200 mA, 250VAC

*Part of W3T107488 - eight vials

DEOX 2000	Old Part No	New Part No.
Chemical pack Comprising:	AAB1098	W3T291579
5 litres acetic acid	U86584	W2T636701
5 litres de-ionised water	U86586	W2T636702
Potassium iodide 250g	AAA8160	W2T633474
Potassium iodate solution	AAB1128	W2T633562

MICRO 2000	Old Part No	New Part No.
Chemical pack Comprising:	AAA7170	W3T291540
Sodium acetate buffer	AAA6723	W2T633388
2.5 litres de-ionised water	AAA6978	W2T633403
Potassium iodide 250g	AAA8160	W2T633474

11 APPENDIX A

MICRO 2000 Reagents

11.1 MICRO/2000® Flow Block Theory of Operation

The measurement of free chlorine is made directly at a buffered pH of 4 with pH 4 buffer or pH of 5 or 6 with carbon dioxide. The measurement of total chlorine is made by reacting the various chlorine species with potassium iodide at the buffered pH, then measuring the resulting iodine concentration.

The analyser measuring process is as follows:

A continuous sample is delivered to the analyser. A flushing Y-strainer divides the sample into two streams—the larger bypass stream continuously flushes the Y-strainer and the smaller stream, about 500 ml/min, flows into the analyser. Most of the flow into the analyser is again bypassed, but a small portion (15 ml) is metered from this flow by a peristaltic metering pump. The reagents, pH 4 buffer or carbon dioxide for the measurement of free chlorine residual and potassium iodide solution with detergent for the measurement of total chlorine residual, are also metered by the same pump. The reagents are then mixed with the sample as the sample is pumped to the analyser cell. A three-electrode amperometric "probe" is immersed in the sample in the cell. A rotating impeller stirs the sample and maintains a constant sample velocity across the electrode surfaces. It also agitates the grit used to clean deposits from the electrodes, improving the stability of calibration. The amperometric cell produces a signal (electrical current) proportional to the oxidant (e.g., chlorine) concentration in the cell.

11.2 Preparation of Reagents - MICRO/2000®

WARNING

Wear recommended protective eyewear when servicing the wet components of the analyser, particularly when servicing reagents and reagent lines. The analyser uses chemicals that can cause severe personal injury by chemical burns on contact with eyes. Rinse any area of contact immediately. If chemicals contact eyes, rinse from eyes and seek immediate medical attention.

WARNING

pH4 buffer and acetic acid will severely irritate eyes and cause chemical burns to skin. Always wear appropriate protective equipment during handling. When diluting acid, always pour the acid into the water, never pour water into acid. Use caution when disconnecting the reagent tubing and avoid contact with any fluid that drips from the open end. It is the responsibility of the user of the equipment to obtain and follow the safety precautions of the manufacturer of the hazardous material.

Chemicals for industrial use: vapour may be harmful if inhaled and may be fatal if swallowed. Liquid may cause severe burns to skin and eyes. Avoid contact with eyes, skin, or clothing. Wash thoroughly after handling. In case of spill, soak up with sand or earth.

When servicing liquid reagent lines, pumps, or refilling reservoirs, turn off pumps to avoid possible squirting of reagent. Observe all safety precautions recommended by the reagent manufacturer or supplier.

WARNING

Handle in accordance with manufacturer's recommendations. Do not mix with other chemicals. Dispose of any chemicals in accordance with all applicable federal, state and local environmental regulations.

The type and number of reagents are determined by the specific application and residual requirements.

11.2.1 Preparation of pH4 Buffer

This reagent is available from Evoqua Water Technologies premixed in one gallon plastic bottles. It may also be made on-site as follows: dissolve 919 grams of sodium acetate, trihydrate in approximately 1.5 litres of distilled water, then mix with 1.73 litres of glacial acetic acid and dilute with distilled water to obtain one gallon of reagent solution.

WARNING

Glacial acetic acid will severely irritate eyes and cause chemical burns to skin. Always wear appropriate protective equipment during handling. When diluting acid, always pour acid into water, never pour water into acid. It is the responsibility of the user of the equipment to obtain and follow the safety precautions of the manufacturer of the hazardous material.

11.2.2 Preparation of Potassium Iodide Solution For MICRO/2000®

NOTICE

Potassium iodide solution is used only in the measurement of total chlorine. Therefore, this section does not apply to analyzers installed to measure free chlorine or potassium permanganate.

Potassium iodide (KI) is added to distilled water and fed into the water sample by the metering pump when measuring total chlorine. The KI reacts with the various forms of chlorine present to release a proportional amount of iodine. The amount of KI required is dependent upon the maximum range of the analyser.

The quantity of KI required is calculated as follows:

$$50 + (4 * \text{range}) = \text{grams KI}$$

Example: Analyser range: 5 mg/l

$$50 + (4 * 5) = 70 \text{ grams KI}$$

CAUTION

Never mix potassium iodide (KI) with sulphuric acid, as free iodine will form immediately.

Analyser range (mg/l)	KI (g/l)	KI (g/2.5 litre bottle)	
		Specific Amount	Typical Amount
0 - 0.5	32	80	100g
0 - 1.0	32	80	
0 - 2.0	35	87.5	
0 - 5.0	41	102.5	200g
0 - 10	50	125	
>10	80	170	

KI either in tablets or in granular form may be used. When using auxiliary KI tablets (W2T614371), one tablet equals 3 grams.

11.2.3 Preparation of Potassium Iodate

Dissolve the correct amount of Potassium Iodate into one gallon (US) by weighing the amount of needed grams into pH4 buffer solution (see chart).

RANGE	PACKAGE NO.	Add amount of grams in US Gallon
± 0.5 mg/l	W2T902405 - 25 grams or W2T902406 - 125 grams	3
± 1.0 mg/l	W2T902405 - 25 grams or W2T902406 - 125 grams	6
± 2.5 mg/l	W2T902405 - 25 grams or W2T902406 - 125 grams	15
± 5.0 mg/l	W2T902405 - 25 grams or W2T902406 - 125 grams	30
± 10.0 mg/l	W2T902405 - 25 grams or W2T902406 - 125 grams	60

11.3 Refilling Reagent Reservoirs

WARNING

To avoid possible severe personal injury or equipment damage, observe the following:

pH4 buffer and acetic acid will severely irritate eyes and cause chemical burns to skin. Always wear appropriate protective equipment during handling. When diluting acid, always pour the acid into the water, never pour water into acid. Use caution when disconnecting the reagent tubing and avoid contact with any fluid that drips from the open end. It is the responsibility of the user of the equipment to obtain and follow the safety precautions of the manufacturer of the hazardous material.

Chemicals for industrial use: vapour may be harmful if inhaled and may be fatal if swallowed. Liquid may cause severe burns of skin and eyes. Avoid contact with eyes, skin, or clothing. Wash thoroughly after handling. In case of spill, soak up with sand or earth.

To avoid cross contamination of the reagents, always use each reservoir for the same reagent. The reservoirs should be clearly labelled with the name of the reagent they contain. To fill reagent reservoirs, loosen and move or remove the threaded cap on the reservoir. Use a funnel when filling reagent reservoirs. The use of a funnel allows the reservoir to be filled without removing the rigid length of tubing from the reservoir. If the tubing is removed from the reservoir, keep it clean. Dirt can clog the tubing. If the tubing is removed from the reservoir while the metering pump is operating, air is drawn into the tubing. This causes a momentary disruption of service until the tubing is returned to the reservoir and the inducted air is purged from the tubing and pump.

11.4 Selection of Reagents

The MICRO/2000® Residual Analyser allows the flexibility to select from several analyser sample conditioning chemicals (reagents). The choice of conditioning chemical is made to provide the best analyser performance while considering chemical cost and handling requirements. Some applications require no chemical conditioning of the analyser sample, while others may require a combination of chemicals. Sample conditioning may be used to provide a stable condition for residual measurement, to eliminate interference from background residuals that are not of interest, and to chemically convert residuals to a form that is conveniently measurable by the analyser. More specifically, the choice of chemicals for analyser sample conditioning in a given application is based on three parameters;

- the residual to be monitored
- other (potentially interfering) residuals present
- water pH and alkalinity

11.4.1 Residual Form

11.4.1.1 Chlorine dioxide and potassium permanganate monitoring

The stability of the sample pH is not as critical when monitoring chlorine dioxide and potassium permanganate residuals as when measuring chlorine residuals. A sample pH change of 0.2 pH units between calibration will cause less than 5% error. Response to chlorine dioxide is somewhat improved at lower pH, however, and for best accuracy (stability) in the monitoring of both residuals, carbon dioxide gas buffering of the analyser sample is recommended. Carbon dioxide will also help prevent deposits caused by water hardness within the wetted analyser components.

11.4.1.2 Bromine residual monitoring

Bromine residuals are often encountered in chlorinated water with a significant bromide residual (e.g. in saline waters). Bromine residual behaves very similarly to chlorine residual and so the application recommendations for each are the same.

11.4.1.3 Chlorine residual monitoring

For the purpose of this description, chlorine species can be grouped as follows:

- 1 Free chlorine - hypochlorous acid and hypochlorite ion
- 2 Chloramines - monochloramine and dichloramine
- 3 Organic chlorine - a broad group of compounds with relatively weak disinfecting and oxidizing potential, a byproduct of chlorination
- 4 Total chlorine - the sum of the above residuals

11.4.1.4 Free chlorine monitoring

In applications where the pH is less than pH8 an is stable, free chlorine residual can be monitored with no chemical conditioning. Often the stability of the water sample pH is not certain and a buffer is used to regulate the analyser sample pH of between pH6 and pH4. If it is important that the analyser function accurately under conditions where the pH of the water sampled may vary, buffering is recommended.

11.4.1.5 Total chlorine monitoring

Potassium iodide liquid reagent must be added to the analyser sample for the measurement of total chlorine residual. The sample pH should be maintained between 4.0 and 4.7. The iodide solution is made by adding potassium iodide to one gallon of unchlorinated DI water.

11.4.1.6 Interfering residuals

Interfering residuals can cause either positive interference (strong oxidants) or negative interference (e.g. organics that combine with chlorine to form organic forms, some of which can behave as free chlorine or may not be detected at all by the standard method of measurement or by the analyser). Decreasing the analyser sample pH (e.g. from pH4 to pH2.5) may, in some applications, cause interference from oxidants but, where acceptable, may also be desirable to improve the response to sluggish organic chlorine compounds in the measurement of potassium permanganate or chlorine dioxide residuals, ammonium sulphate reagent liquid is used to eliminate the response (interference) to free chlorine when necessary. The MICRO 2000 Residual Analyser allows the flexibility to select from several analyser sample conditioning chemicals (reagents). The choice of conditioning chemical is made to provide the best analyser performance while considering chemical cost and handling requirements. Some applications require no chemical conditioning of the analyser sample while others may require a combination of chemicals. Sample conditioning may be used to provide a stable condition for residual measurement, to eliminate interference from background residuals which are not of interest and to chemically convert residuals to a form which is conveniently measurable by the analyser.

Specifically, the choice of chemicals for analyser sample conditioning in a given application is based on three parameters - the residual to be monitored, other (potentially interfering) residuals present and water pH and alkalinity.

12 APPENDIX B

DEOX/2000® Reagents

12.1 DEOX/2000® Theory Of Operation

When a process requires super chlorination the effluent from it will have to be dechlorinated to some extent to allow discharge, either to a sewer or a natural water source. A variety of methods are available for dechlorination depending on the concentration of chlorine to be removed, the most common being the reaction of chlorine species in the water with sulphur dioxide (SO₂) or sodium bisulphite (NaHSO₃)

A range of chlorine species is typically present in industrial processes, these ranging from hypochlorous acid (HOCl) to combined chlorine such as chloramines. The reaction with SO₂ for these species is indicated below.

The initial step is for the formation of sulphurous acid:

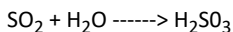

This reacts with chlorine species as follows:

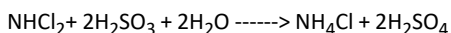
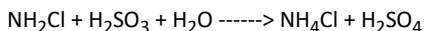
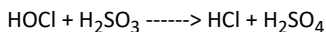

This reaction with sodium bisulphite is:

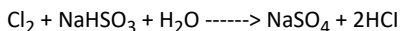

The reactions show that both free and combined chlorine can be removed. Dechlorination byproducts are ammonium chloride (NH₄Cl), a salt, hydrochloric acid (HCl) and sulphuric acid (H₂SO₄). These are naturally neutralised by calcium carbonate (CaCO₃) in the water, the result being a reduction in the hardness of the water. When SO₂ is used each mg/l of chlorine removed results in 2.8mg/l of hardness reduction and when NaHSO₃ is used, 1.38 mg/l of hardness is removed.

The stoichiometric relationship means that for every mg/l chlorine, 0.9 mg/l SO₂ is required (often this is increased to 1.05 to ensure complete dechlorination) while for sodium bisulphite, 1.46 mg/l must be used. The alkalinity of chlorinated wastewater effluent is usually in the region of 150 to 200 mg/l as CaCO₃. Therefore if SO₂ is used, dechlorination of 10 mg/l would result in a 28 mg/l reduction in alkalinity, and for NaHSO₃, the result would be 14 mg/l reduction.

The process has to be controlled by a dechlorination monitor. This can be done in a number of ways. A traditional chlorine monitor can be used to control the process to zero chlorine residual. The disadvantage with this approach is that the monitor only responds to the chlorine residual and not SO₂. Hence the zero of the instrument is zero chlorine, addition of SO₂ beyond this will not be detected and there is a possibility of excessively dosing SO₂, especially if there is a long process time.

An alternative approach is to use a centre zero analyser such as the SFC DEOX/2000®. In this approach an iodine bias is applied to the cell. Iodine (I₂) is reduced in the cell analogous to chlorine Cl₂ and hence a zero current is established. The presence of chlorine results in both the I₂ and the Cl₂ being reduced which creates a current greater than the zero current. The presence of SO₂ results in a reaction with I₂ which decrease the I₂ bias in the cell. This yields a current lower than the zero current. This is achieved by the following chemistry.

Iodine is not stable long term and hence has to be generated in the cell. Using a peristaltic pump, Potassium Iodate (KIO₃) and an excess of Potassium Iodide (KI) are mixed in a acid solution.

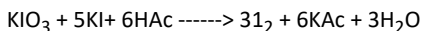

This is constantly fed to the cell to create the zero current bias, the feed rate being 0.08 ml/min of reagents in total, i.e. negligible compared to the volume of water being treated.

The reactions are then as follows:

If excess chlorine is present, this reacts with excess KI in the analyser as follows:-

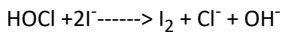

Every mg/l of chlorine produces an extra mg/l of I₂ which adds to the zero current signal.

If excess SO₂ is present, this reacts as follows:

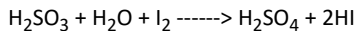
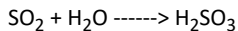

Every mg/l of SO₂ reacts with a mg/l of I₂ and reduces the zero current signal. These reactions are illustrated in the following graph.

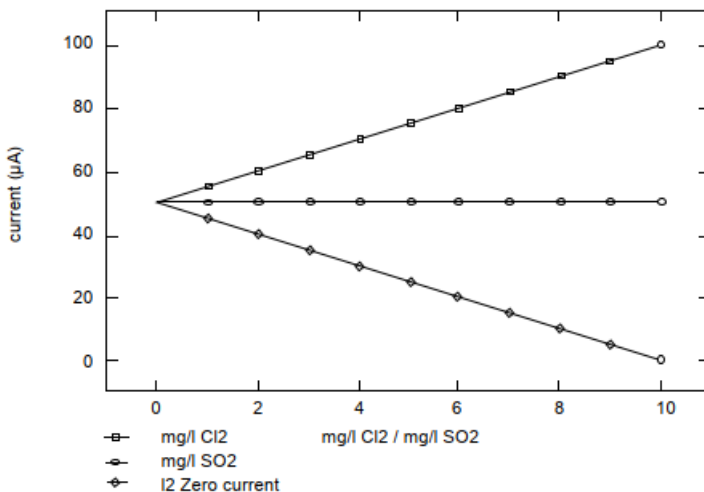

12.2 Preparation of Reagent DEOX/2000®

WARNING

Wear recommended protective goggles when servicing the wet components of the analyser, particularly when servicing reagents and reagent lines. The analyser uses chemicals that can cause severe personal injury by chemical burns on contact with eyes. Rinse any area of contact immediately. If chemicals contact eyes, rinse with copious amounts of water and seek immediate medical attention.

WARNING

pH4 buffer and acetic acid will severely irritate eyes and cause chemical burns to skin. Always wear appropriate protective equipment during handling. When diluting acid, always pour the acid into the water, never pour water into acid. Use caution when disconnecting the reagent tubing and avoid contact with any fluid that drips from the open end. It is the responsibility of the user of the equipment to obtain and follow the safety precautions of the manufacturer of the hazardous material.

WARNING

Chemicals for industrial use: vapour may be harmful if inhaled and may be fatal if swallowed. Liquid may cause severe burns to skin and eyes. Avoid contact with eyes, skin, or clothing. Wash thoroughly after handling. In case of spill, soak up with sand or earth.

WARNING

When servicing liquid reagent lines, pumps, or refilling reservoirs, turn off pumps to avoid possible squirting of reagent. Observe all safety precautions recommended by the reagent manufacturer or supplier.

12.3 Preparation of Potassium Iodide Solution for DEOX/2000®

Potassium Iodide (KI) solution is prepared by dissolving 166g KI in 5 litres of distilled water. The Potassium Iodate (KIO_3) reagent is prepared by adding KIO_3 concentrate to the Acetic acid. The table below is used to determine the quantity.

Measuring Range	Volume of KIO_3 (mls)
±0.5mg/l	50
±1.0 mg/l	100
±2.mg/l	250

The reagents are placed in the cabinet and one reagent tube is placed in the KI solution whilst the other is placed in the Acetic acid solution.

NOTICE

If the bias cannot be achieved add an additional 20% of the Iodate standard.

13 EU Declaration of Conformity



EU Declaration of Conformity

No. KAC10194

Manufacturer: Evoqua Water Technologies Ltd

Address: One60 London Road
Sevenoaks
Kent
TN13 1BT
UK

Product Designation: MICRO 2000 / DEOX 2000 MEASUREMENT MODULE
W3T140748 / W3T332446

This declaration has been issued under the sole responsibility of the manufacturer.

The object of the declaration is in conformity with the relevant Union harmonisation legislation:

- 2014/30/EU** Council Directive on the harmonisation of the laws of the Member States relating to electromagnetic compatibility. (EMC Directive)
Further information about the conformity to this Directive is given in annex A
- 2014/35/EU** Council Directive on the harmonisation of the laws of Member States relating to the making available of electrical equipment designed for use within certain voltage limits. (Low Voltage Directive)
Further information about the conformity to this Directive is given in annex A

Sevenoaks, 7th September 2016

Fletcher Roche
Business Director, Wallace & Tiernan UK

Annex A is an integral part of this declaration.
This declaration certifies the compliance with the indicated directives but implies no warranty of properties.
The safety instructions of the accompanying product documentation shall be observed.

KAC10194 Issue 3



Annex A to the EU Declaration of Conformity

No. KAC10194

Product Designation: MICRO 2000 / DEOX 2000 MEASUREMENT MODULE
W3T140748 / W3T332446

The conformity of the designated product with the provisions of the Directive **2014/30/EU** is proved by full compliance with the following standards:

Harmonised European Standards:

Reference number : Date	Title
BS EN 61326-1:2013	Electrical equipment for measurement, control and laboratory use – EMC requirements. General requirements.

Note: Product was tested as a system with SFC Analyser.

The conformity of the designated product with the provisions of the Directive **2014/35/EU** is proved by full compliance with the following standards:

Harmonised European Standards:

Reference number : Date	Title
BS EN 61010-1:2010	Safety requirements for electrical equipment for measurement, control, and laboratory use. General requirements.

KAC10194 Issue 3

Evoqua Water Technologies

Aftermarket Support and Service

INTRODUCTION

Every day, millions of people and thousands of companies rely on Evoqua Water Technologies to help them meet their needs for clean water.

As the leading global provider of chemical dosing, metering, disinfection, chlorination, filtration, deionisation and electrochlorination products, Evoqua Water Technologies provide systems and process technology for water treatment in the municipal, industrial and the leisure industries.

AFTERMARKET SUPPORT AND SERVICE

Meeting our customers needs is our highest priority. In addition to supplying the products you need, we also offer a full range of aftermarket support and service options. Our dedicated team of highly skilled engineers are committed to providing a first class service to our customers.

Getting the correct level of aftermarket support and service can ensure that your plant runs as efficiently as possible by preventing breakdowns and minimising plant downtime.

Our modular flexible approach ensures that our aftermarket support and service offering can be tailored to meet your exact requirements, our offering includes:

- Technical Assistance
- 24 Hour Telephone Support
- Breakdown Cover
- Maintenance Contracts
- Planned & Preventative Maintenance Programs
- Call-Out Service
- Supply of Spare Parts and Critical Spares
- System Refurbishments & Upgrades

CO-ORDINATION

Evoqua Water Technologies dedicated Customer Service Department is co-ordinated from our Derby office.

Tel: - 0845 450 2882

customerservice.uk@evoqua.com

COMMISSIONING

Following installation, our team of commissioning engineers are responsible for the safe handover of the equipment from ourselves to the new owner guaranteeing its operability in terms of performance, reliability and safety.

All our commissioning engineers undergo a comprehensive training programme on our products and the latest industry and health and safety standards.

In our team we have commissioning engineers who are trained to work in all industry sectors both on shore and offshore.

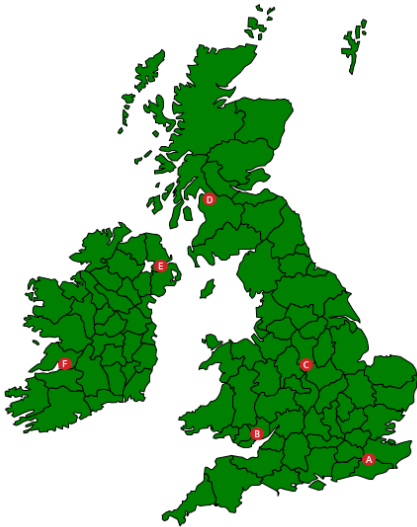

FULL COVERAGE UK & IRELAND

Over the years we have been able to grow our aftermarket support and service operation considerably. To ensure our customers get the very best support and shortest response times our engineers and support staff are strategically located across the country, to give us the very best coverage of the whole of the UK & Ireland.

A - Sevenoaks, Kent

B - Caldicot, Gwent

C - Little Eaton, Derbyshire

D - Kirkintilloch, East Dunbartonshire

E - Belfast, Northern Ireland

F - Limerick, Ireland

Did you know?

Evoqua Water Technologies has over 200 current service and maintenance contracts in mainland UK & Ireland and carry out over 2000 site visits per year.

Did you know?

Our skilled engineers carry work in all industries including; life sciences, food & beverage and leisure.

TRAINING

Evoqua Water Technologies understands the importance of training to our customers; receiving the correct training can ensure that you get the optimum performance out of our equipment and your plant.

Our team of qualified trainers can put together bespoke training solutions tailored to suit your needs. This could either be classroom based, or hands-on operator training, conducted onsite or at one of our locations around the country.

We have also found training creates stronger links with our customers and it gives us a better opportunity to understand each others requirements.

NOTES

NOTES

Wallace & Tiernan® Products worldwide

Australia

+61 1300 661 809
info.au@evoqua.com

Canada

+1 905 944 2800
wtoc.can@evoqua.com

China

+86 21 5118 3777
sales.cn@evoqua.com

France

+33 1 41 15 92 20
wtfra@evoqua.com

Germany

+49 8221 9040
wtger@evoqua.com

Singapore

+65 6559 2600
sales.sg@evoqua.com

UK

+44 300 124 0500
info.uk@evoqua.com

USA

+1 800 524 6324
wt.us@evoqua.com

